

The compact, proven design has high efficiency and guaranteed operation for heating and air conditioning.

The water within the installation contains air which can form corrosion and reduce the thermal transfer. A Flexvent is fitted at places where the air collects.

#### Advantages

- The cap of the Flexvent Super is conical in shape. The advantage of this construction is that the clearance between the water level and venting valve is maximized.
- The air escape duct can be opened or closed with an adjusting screw.
- The venting valve forms an integral part of the cap, so that it is impossible to damage the float vent mechanism from outside.

#### Technical Specifications

- Minimum/Maximum working temperature: -10 °C / 120 °C.
- Minimum/Maximum working pressure: 0.2 / 10.0 bar.
- Suitable for addition of glycol-based anti-freeze up to 50%.
- Suitable for addition of ethanol-based anti-freeze up to 30%.



Description	Flexvent Super G $\frac{1}{2}$ "F	
Order Code	28520	
GTIN	08712874285200	
Model	<u>Flexvent Super</u>	
Dimensions	Ø [mm]	73
	H. [mm]	119
Connection	G $\frac{1}{2}$ " F	
Shut-off valve	no	

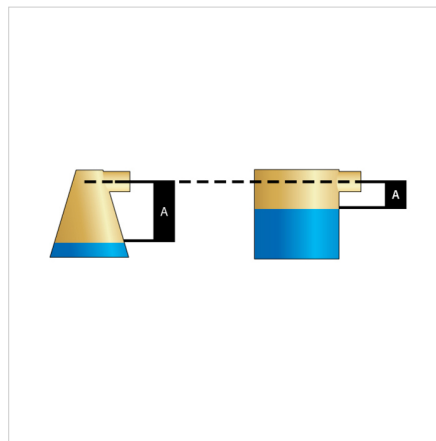
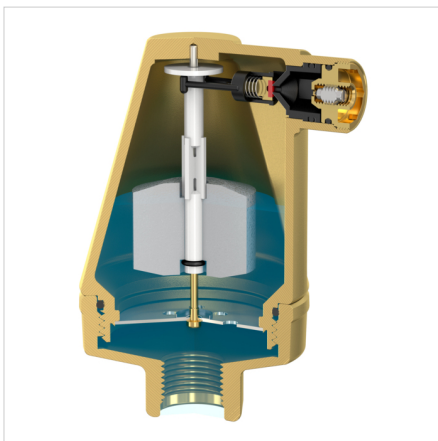



### Classification General Data

<b>Etim Group</b>	Filters/separators
<b>Etim Class</b>	De-aerator (automatic)
<b>Product Name</b>	Flexvent Super G1/2"F
<b>Brand</b>	FLAMCO
<b>Product Type</b>	Flexvent
<b>Order Code</b>	28520
<b>GTIN</b>	08712874285200

### Attributes

<b>Housing material</b>	Brass
<b>Housing material</b>	Brass
<b>Material valve</b>	Other
<b>Material float</b>	Other
<b>Nominal diameter</b>	1/2 inch (15)
<b>Outer pipe diameter</b>	21.3 Millimetre
<b>Connection 1</b>	Internal thread cylindrical BSPP-G (ISO 228-1)
<b>Maximum pressure at 20 C</b>	10 Bar
<b>Max. operating pressure at 20 °C</b>	10 Bar
<b>Flange compression class</b>	PN 10
<b>Max. medium temperature (continuous)</b>	120 Degrees celsius
<b>Surface protection</b>	Untreated
<b>Length of connection 1</b>	74 Millimetre
<b>Working length connection 1</b>	119 Millimetre
<b>Height</b>	119 Millimetre
<b>Lockable</b>	No
<b>With leakage protection</b>	Yes
<b>With air intake barrier</b>	Yes

### Find more information online:

[Installation and operating instruction](#)

[Statement of Conformity](#)

[Flexvent Super ADSK](#)

[Flexvent Super DWG](#)

[Flexvent Super STEP](#)

[Folder](#)

[Flexvent Life Cycle Assessment](#)

[Packaging data](#)

Fort Blauwkapel 1  
1358 DB, Almere - nl

T +31 (0)36 52 62 300  
E [info@aalberts-hfc.com](mailto:info@aalberts-hfc.com)  
I [flamcogroup.com](http://flamcogroup.com)