



Data sheet

Hydraulic data

Maximum operating pressure P_N	10 bar
Head max H_{max}	6.1 m
Flow max Q_{max}	3.0 m ³ /h
Min. fluid temperature T_{min}	-10 °C
Max. fluid temperature T_{max}	95 °C
Min. ambient temperature T_{min}	-10 °C
Max. ambient temperature T_{max}	40 °C

Motor data

Energy efficiency index (EEI)	≤0.20
Mains connection	1~230 V ±10%, 50/60 Hz
Rated power P_2	30 W
Min. speed n_{min}	700 1/min
Max. speed n_{max}	4200 1/min
Power consumption $P_{1 min}$	4 W
Power consumption $P_{1 max}$	40 W
Emitted interference	EN 61000-6-3
Interference resistance	EN 61000-6-2
Electromagnetic compatibility	EN 61800-3
Threaded cable connection	1 x PG11
Insulation class	F
Protection class	IPX2D

Materials

Pump housing	Grey cast iron
Impeller	PP-GF40
Shaft	Stainless steel
Bearing	Carbon, metal-impregnated

Installation dimensions

Pipe connection on the discharge side DN_d	G 1½
Pipe connection on the suction side DN_s	G 1½
Port-to-port length L_0	180 mm

Pump curves

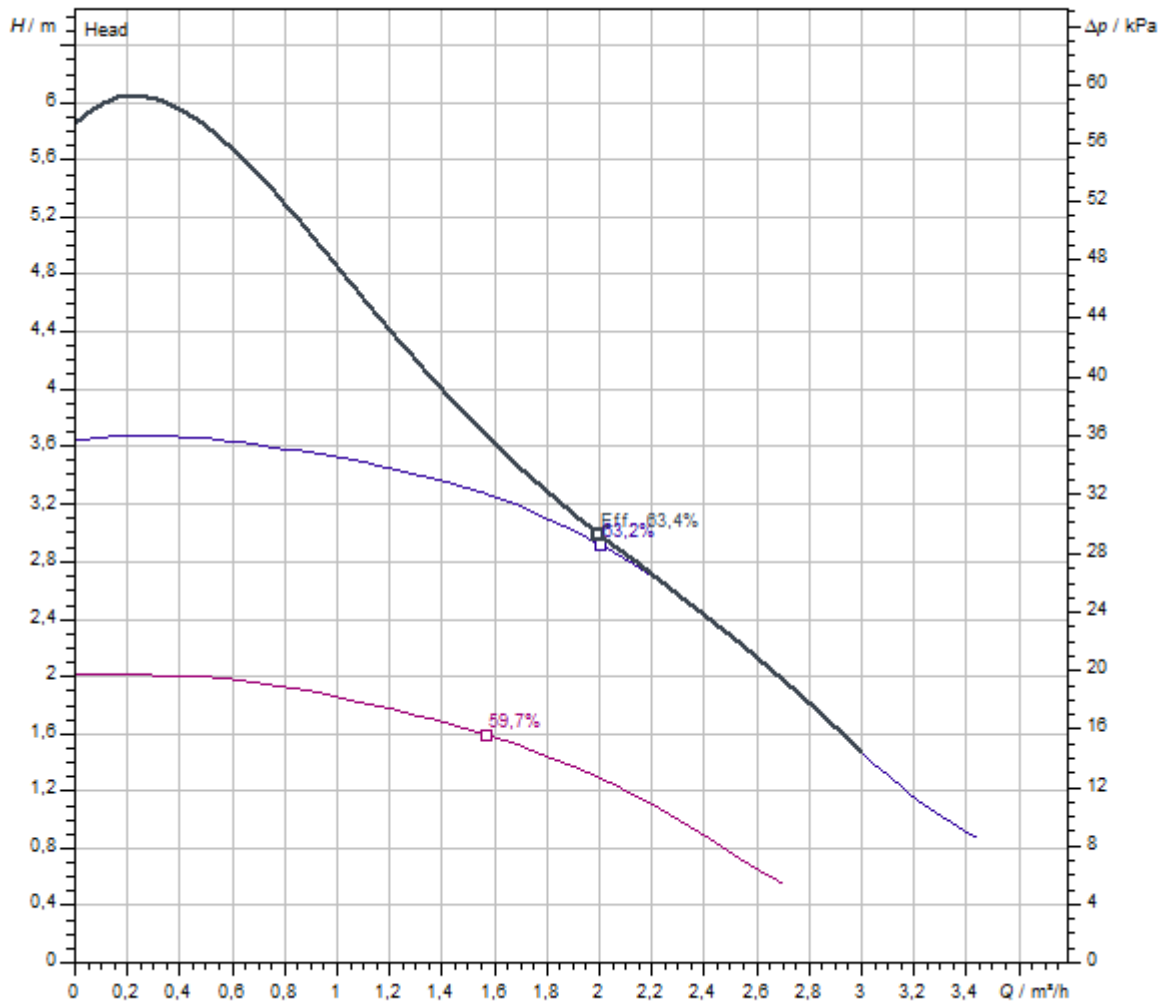

Fluid media	Water 100 %
Fluid temperature <i>T</i>	20,00 °C
speed at duty point <i>n hydr. @ OP</i>	2.900 1/min

Dimensions and dimensions drawings

Atmos PICO 25/1-6

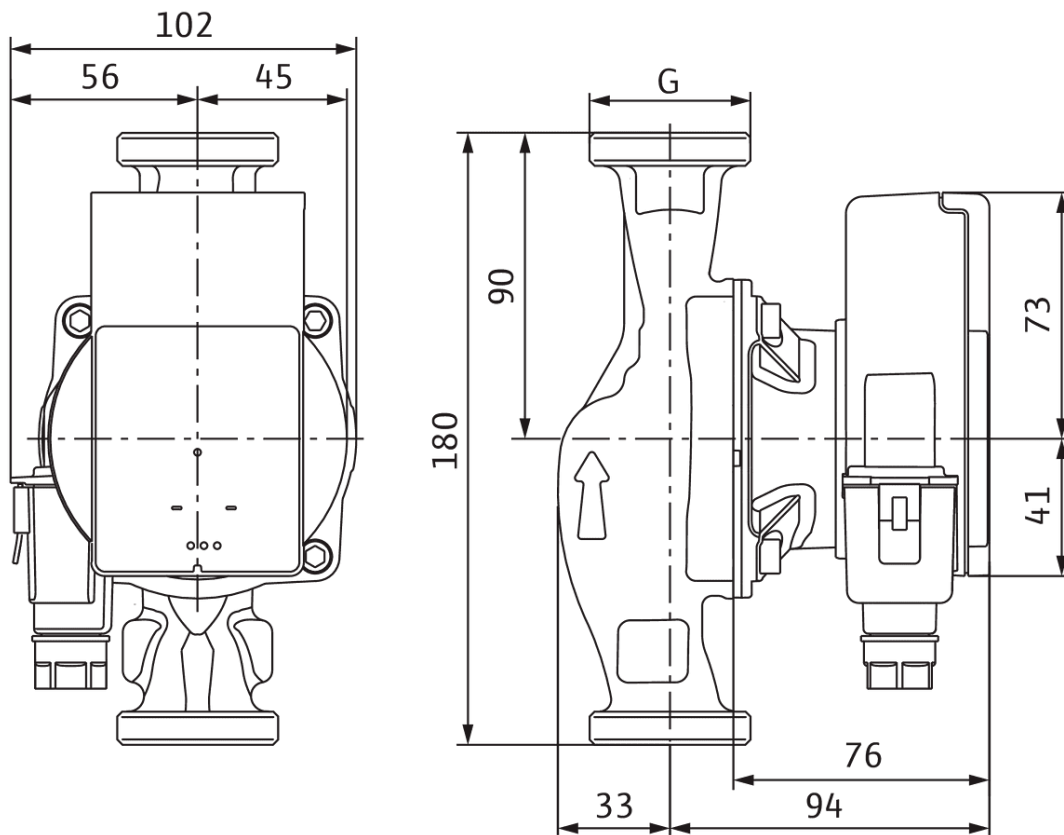

Wiring diagram

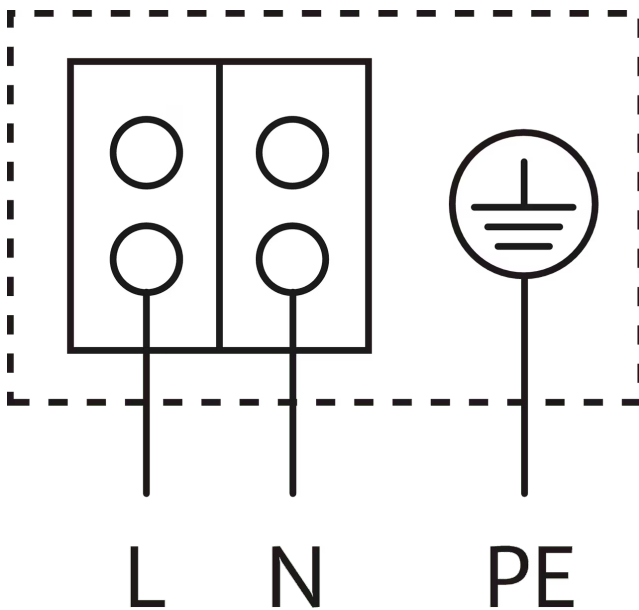

Blocking current-proof motor

Single-phase motor (EM) 2-pole - 1~230 V, 50 Hz

Ordering information

Product data

Brand	Wilo
Product description	Atmos PICO 25/1-6
Article number	4232694 
EAN number	4048482932774
Colour	Green
Minimum order quantity	1
Date of sales availability	2019-09-01

Packaging

Packaging type	Cardboard box
Packaging property	Sales packaging
Pieces per pallet	198
Number per layer	24

Dimension, weight

Length with packaging	194 mm
Length <i>L</i>	180 mm
Height with packaging	105 mm
Height <i>H</i>	102 mm
Width with packaging	174 mm
Width <i>W</i>	127 mm
Gross weight, approx. <i>m</i>	2 kg
Net weight, approx. <i>m</i>	1.8 kg

Tender text

High-efficiency pump Wilo-Atmos PICO, electronically controlled. Maintenance-free glandless circulator with screwed connection, blocking-current proof synchronous motor according to ECM technology and built-in electronic power control for variable differential pressure control. Can be used for all heating and air-conditioning applications.

Standard-equipped with:

- Preselectable control modes for optimum load adjustment:
 - Variable differential pressure ($\Delta p-v$), with 3 pre-defined characteristic curves,
 - Constant speed (3 constant speed stages)
- LED display of selected control mode
- LED display of selected characteristic curve in the control mode
- Signal display
 - LED is lit up in green in normal operation
 - LED lights up/flashes in case of a fault
- Minimal consumption only 4 W
- Integrated motor protection
- Automatic deblocking function
- High starting torque

Pump housing made of grey cast iron, impeller made of polypropylene, stainless steel shaft with metal-impregnated carbon friction bearings.

Operating Data

Min. fluid temperature T_{\min}	-10 °C
Max. fluid temperature T_{\max}	95 °C
Min. ambient temperature T_{\min}	-10 °C
Max. ambient temperature T_{\max}	40 °C
Maximum operating pressure PN	10 bar

Motor data

Energy efficiency index (EEI)	≤ 0.20
Mains connection	1~230 V $\pm 10\%$, 50/60 Hz
Rated power P_2	30 W
Min. speed n_{\min}	700 1/min
Max. speed n_{\max}	4200 1/min
Power consumption $P_{1 \min}$	4 W
Power consumption $P_{1 \max}$	40 W
Emitted interference	EN 61000-6-3
Interference resistance	EN 61000-6-2
Electromagnetic compatibility	EN 61800-3
Insulation class	F
Protection class	IPX2D
Threaded cable connection	1 x PG11

Materials

Pump housing	Grey cast iron
Impeller	PP-GF40
Shaft	Stainless steel
Bearing	Carbon, metal-impregnated

Installation dimensions

Pipe connection on the suction side <i>DN_s</i>	G 1½
Pipe connection on the discharge side <i>DN_d</i>	G 1½
Port-to-port length <i>L₀</i>	180 mm

Ordering information

Brand	Wilo
Product description	Atmos PICO 25/1-6
Net weight, approx. <i>m</i>	1.8 kg
Article number	4232694 