

Full lift safety valve / Standard safety valve

ARI-SAFE

**Full lift safety valve D/G
Standard safety valve F**

- Type-test approved acc. to TRD and AD2000-A2
- TÜV · SV · . . . -663 · D/G **Figure 901-912**
- TÜV · SV · . . . -663 · F **Figure 901/911**
- Further approvals: see inside

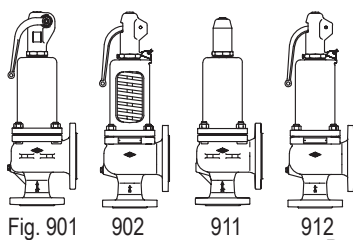

Fig. 901 902 911 912
Page 2

ARI-SAFE

**Standard safety valve
for the heating technology**

- Type-test approved acc. to TRD 721
- TÜV · SV · . . . -688 · D/G/H **Figure 903**
- TÜV · SV · . . . -688 · D **Figure 904**

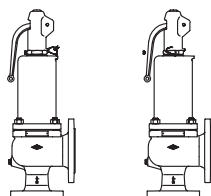

Fig. 903 904
Page 6

ARI-SAFE-P

Standard safety valve D/G/F

- Type-test approved acc. to TRD and AD2000-A2
- TÜV · SV · . . . -811 · D/G **Figure 921-924**
- TÜV · SV · . . . -811 · F **Figure 921/923**

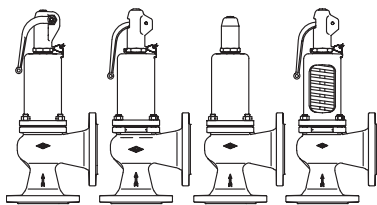

Fig. 921 922 923 924
Page 12

ARI-SAFE-TC

**Full lift safety valve D/G
Standard safety valve F**

- Type-test approved acc. to TRD and AD2000-A2
- TÜV · SV · . . . -995 · D/G **Figure 941-943**
- TÜV · SV · . . . -995 · F **Figure 941/943**

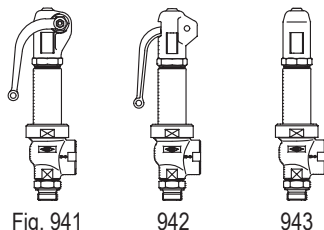

Fig. 941 942 943
Page 16

ARI-SAFE-TC

**Standard safety valve
for the heating technology**

- Type-test approved acc. to TRD 721
- TÜV · SV · . . . -997 · D/G/H **Figure 945**
- TÜV · SV · . . . -997 · D **Figure 946**

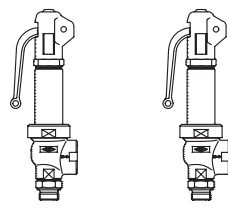

Fig. 945 946
Page 20

ARI-SAFE-TCP

Standard safety valve D/G/F

- Type-test approved acc. to AD2000-A2
- TÜV · SV · . . . -1041 · D/G/F **Figure 961-963**

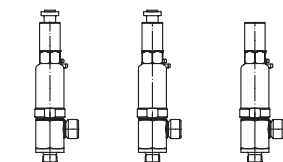

Fig. 961 962 963
Page 24

ARI-SAFE-TCS

Standard safety valve D/G/F

- Type-test approved acc. to AD2000-A2
- TÜV · SV · . . . -1041 · D/G/F **Figure 951-953**

FOR HORIZONTAL APPLICATION

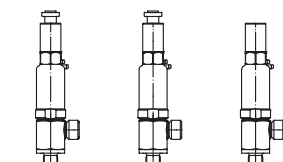

Fig. 951 952 953
Page 28

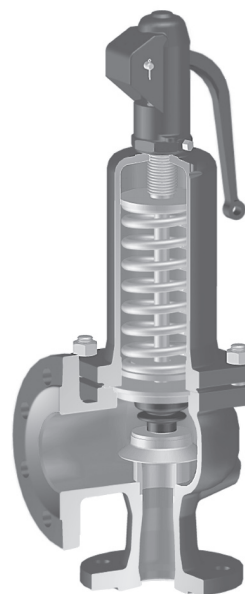

Fig. 900



Fig. 940

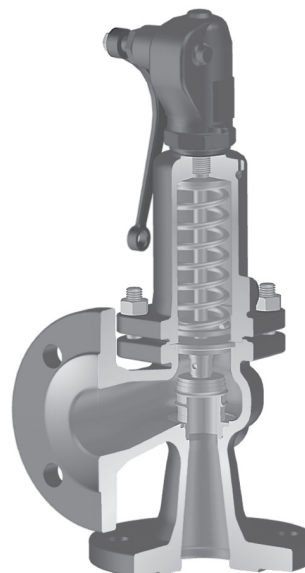

Fig. 920



Fig. 950/960

Features:

- Direct loaded with spring
- Wear resistant seat/disc
- Precision disc alignment and guide
- Possible with soft seal disc
- Possible with EPDM bellow
- Possible with stainless steel bellow
- ARI-SAFE-TC/TCP/TCS:
All common thread types

ARI-SAFE - Full lift safety valve D/G, Standard safety valve F

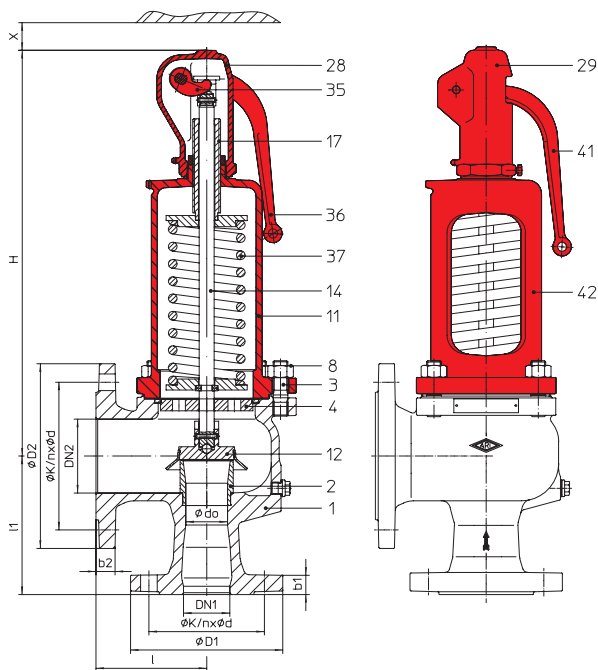

Fig. ... 901
closed lifting device

Fig. ... 902
open lifting device

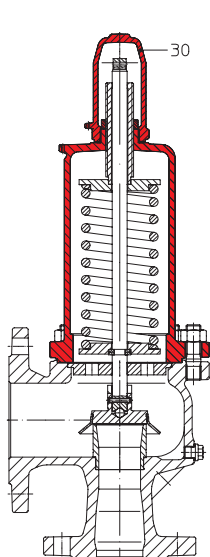

Fig. ... 911
gas-tight cap

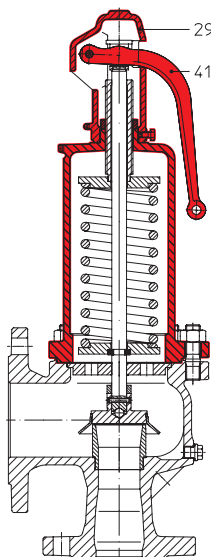

Fig. ... 912
open lifting device

Figure	Nominal pressure	Material	Nominal diameter
12.901 / 902 / 911 / 912	PN16/16	EN-JL1040	DN20/32 - 150/250
25.901 / 902 / 911 / 912	PN40/16	EN-JS1049	DN20/32 - 100/150
35.901 / 902 / 911 / 912	PN40/16	1.0619+N	DN20/32 - 150/250
55.901 / 911	PN40/16	1.4408	DN20/32 - 100/150
Figure	Temperature range	Flange	Flange holes/-thickness tolerances
12.901 / 902 / 911 / 912	-10°C to +300°C	DIN EN 1092-2	DIN 2533/2533
25.901 / 902 / 911 / 912	-10°C to +350°C	DIN EN 1092-2	DIN 28607/28605
35.901 / 902 / 911 / 912	-10°C to +450°C	DIN EN 1092-1	DIN 2545/2543
55.901 / 911	-60°C to +400°C	DIN EN 1092-1	DIN 2545/2543

Type-test approval
 Full lift safety valve: TÜV · SV · · -663 · D/G (Stand. valve 0,2-0,5 bar)
 Standard safety valve: TÜV · SV · · -663 · F DN 20-150
 Set gauge pressure refer to „Capacity“.

Requirement
 Acc. to EN ISO 4126-1, VdTÜV-leaflet 100, AD2000-A2, TRD 421, material selection observe TRB 801 No. 45!!

Construction
 Safety valve, spring loaded, direct loaded

Sizing
 For steam, air and water see capacity tables, calculation acc. to EN ISO 4126-1, TRD 421 and AD2000-A2.

Details required

- Medium gasform: Mass flow (kg/h), molar mass (kg/kmol), temperature (°C), set gauge pressure (bar), back gauge pressure (bar)
- Medium liquid: Mass flow (kg/h), density (kg/m³), viscosity, temperature (°C), Set gauge pressure (bar), back gauge pressure (bar)

Order data:
 ARI-SAFE-Safety valve,
 Figure ..., DN .../..., PN ..., Material ..., Set gauge pressure ...bar

Selection of possible applications
 Chemical Industry, processing industry, plant manufacturing
 (other applications on request)

Selection of possible flow media
 EN-JL1040, EN-JS1049 1.0619+N: Steam, neutral gases, vapours and liquids
 1.4408: Steam, aggressive gases, vapours and liquids
 (other flow media on request)

	without metal bellow	with metal bellow
Superimposed back pressure	no backpressure allowed	on request
Built up back pressure	max. 10% from set pressure (gauge) (higher on request)	on request

Dimensions and weights

DN1/DN2	(mm)	20/32	25/40	32/50	40/65	50/80	65/100	80/125	100/150	125/200	150/250	
d ₀	(mm)	18	22,5	29	36	45	58,5	72	90	106	125	
A ₀	(mm ²)	254	398	661	1018	1590	2688	4072	6362	8825	12272	
l	(mm)	85	100	110	115	120	140	160	180	200	225	
l1	(mm)	95	105	115	140	150	170	195	220	250	285	
H	(mm)	270	280	330	390	435	545	610	690	845	890	
H (Bellow design)	(mm)	310	335	390	445	500	620	690	770	--	--	
X	(mm)	150	150	200	250	300	350	400	500	500	500	
Drainhole with plug ¹⁾	(inch)	G 1/4"					G 3/8"					
Weight	(kg)	8,5	10	14	20	28	40	53	80	125	165	
Weight (Bellow design)	(kg)	9,5	11,5	16	22,5	32	47	59	90	--	--	

Standard-flange dimensions refer to page 34.

¹⁾ Standard for EN-JL1040, EN-JS1049 1.0619+N, optional at 1.4408

Spring ranges: Standard design (barg)

DN20	DN25 - 50	DN65	DN80	DN100	DN125	DN150
0,2 - 0,5	0,2 - 0,5	0,2 - 0,5	0,2 - 0,5	0,2 - 0,5	0,2 - 0,4	0,2 - 0,5
0,52 - 1	0,52 - 1	0,52 - 1	0,52 - 1	0,52 - 1	0,42 - 0,75	0,52 - 1
1,05 - 1,5	1,05 - 1,5	1,05 - 1,5	1,05 - 1,5	1,05 - 1,5	0,77 - 1,1	1,05 - 1,5
1,55 - 2,5	1,55 - 2	1,55 - 2	1,55 - 2	1,55 - 2	1,15 - 1,5	1,55 - 1,9
2,55 - 4,5	2,05 - 2,7	2,05 - 2,7	2,05 - 2,7	2,05 - 2,5	1,55 - 1,9	1,95 - 2,3
4,6 - 8,5	2,75 - 3,6	2,75 - 3,6	2,75 - 3,6	2,55 - 3	1,95 - 2,5	2,35 - 2,7
8,6 - 19	3,7 - 5	3,7 - 5	3,7 - 5	3,05 - 3,6	2,55 - 2,95	2,75 - 3,3
19,1 - 28	5,1 - 9	5,1 - 9	5,1 - 9	3,7 - 5	3 - 4	3,35 - 4,1
28,1 - 35	9,1 - 16	9,1 - 16	9,1 - 14	5,1 - 9	4,1 - 5,7	4,2 - 5,5
35,1 - 40	16,1 - 22	16,1 - 22	14,1 - 19	9,1 - 14	5,8 - 8,2	5,6 - 7,4
	22,1 - 28	22,1 - 28	19,1 - 25	14,1 - 19	8,3 - 12	7,5 - 11
	28,1 - 34			19,1 - 24	12,1 - 17	11,1 - 16
					17,1 - 24	16,1 - 21
					24,1 - 27	21,1 - 26

Spring ranges: Bellow design (barg)

DN20	DN25	DN32	DN40	DN50	DN65	DN80	DN100
3,0 - 3,7	2,5 - 3,3	2,5 - 3,2	2,6 - 3,6	2,8 - 3,4	2,5 - 3,7	2,5 - 3,3	2,5 - 3,5
3,8 - 4,6	3,4 - 4,6	3,3 - 4,0	3,7 - 4,5	3,5 - 4,5	3,8 - 4,6	3,4 - 4,5	3,6 - 4,2
4,7 - 6,3	4,7 - 5,4	4,1 - 5,5	4,6 - 5,6	4,6 - 8,4	4,7 - 5,9	4,6 - 5,8	4,3 - 4,9
6,4 - 8,4	5,5 - 7,0	5,6 - 6,4	5,7 - 7,5	8,5 - 10,0	6,0 - 8,0	5,9 - 7,5	5,0 - 5,6
8,5 - 10,2	7,1 - 9,0	6,5 - 7,9	7,6 - 10,0	10,1 - 11,5	8,1 - 10,0	7,6 - 8,9	5,7 - 7,0
10,3 - 13,0	9,1 - 11,7	8,0 - 11,5	10,1 - 12,5	11,6 - 16,0	10,1 - 18,0	9,0 - 10,5	7,1 - 8,0
13,1 - 17,0	11,8 - 16,0	11,6 - 18,5	12,6 - 16,0	16,1 - 18,5		10,6 - 13,0	8,1 - 9,3
17,1 - 27,5	16,1 - 22,0	18,6 - 25,0	16,1 - 22,0	18,6 - 23,0		13,1 - 14,0	9,4 - 11,5
	22,1 - 30,0						11,6 - 13,0

Design with bellow as standard valve (only Fig. 901/911)

Parts

Pos.	Description	Fig. 12.901/902/911/912	Fig. 25.901/902/911/912	Fig. 35.901/902/911/912	Fig. 55.901/911
1	Body	EN-GJL-250 , EN-JL 1040	EN-GJS-400-18U-LT, EN-JS1049	GP240GH+N, 1.0619+N	GX5CrNiMo19-11-2, 1.4408
2	Seat	X6CrNiMoTi17-12-2, 1.4571			
3	Studs	25CrMo4, 1.7218			A4 - 70
4	Spindle guide	X20Cr13+QT, 1.4021+QT			
8	Hexagon nut	C35E, 1.1181			
11	Bonnet, closed	EN-GJL-250 , EN-JL 1040	EN-GJS-400-18U-LT, EN-JS1049		GX5CrNiMo19-11-2, 1.4408
12	Disc unit	X39CrMo17-1+QT, 1.4122+QT			
14	Spindle *	X20Cr13+QT, 1.4021+QT			
17	Adjusting screw	X20Cr13+QT, 1.4021+QT			
28	Cap, closed	EN-GJL-250 , EN-JL 1040	EN-GJS-400-18U-LT, EN-JS1049		GX5CrNiMo19-11-2, 1.4408
29	Cap, open	EN-GJL-250 , EN-JL 1040	EN-GJS-400-18U-LT, EN-JS1049		GX5CrNiMo19-11-2, 1.4408
30	Cap, gastight	EN-GJL-250 , EN-JL 1040	EN-GJS-400-18U-LT, EN-JS1049		GX5CrNiMo19-11-2, 1.4408
35	Lift fork	EN-GJS-400-18U-LT, EN-JS1049			
36	Lever, closed	EN-GJS-400-18U-LT, EN-JS1049			
37	Spring *	51CrV4, 1.8159			
41	Lever, open	EN-GJS-400-18U-LT, EN-JS1049			
42	Bonnet, open	EN-GJL-250 , EN-JL 1040	EN-GJS-400-18U-LT, EN-JS1049		--
43	Bellow (optional)	EPDM			
55	Bellow unit (optional)	X6CrNiMoTi17-12-2, 1.4571			
70	Balanced piston (optional)	X6CrNiMoTi17-12-2, 1.4571			

* Spare parts

Information / restriction of technical rules need to be observed!

ARI-Valves of EN-JL1040 are not allowed to be operated in systems acc. to TRD 110.

A production allowance acc. to TRB 801 No. 45 exists (acc. to TRB 801 No. 45 EN-JL1040 is not allowed.)

The engineer, designing a system or a plant, is responsible for the selection of the correct valve.

Capacity saturated steam / air incl. 10% overpressure

Set gauge pressure			I Saturated steam (kg/h)										II Air 0°C and 1.013 bara (Nm³/h)							
bar	DN 20		DN 25		DN 32		DN 40		DN 50		DN 65		DN 80		DN 100		DN 125		DN 150	
	I	II	I	II	I	II	I	II	I	II	I	II	I	II	I	II	I	II	I	II
0,2	81	95	126	148	210	246	324	380	506	594	855	1003	1295	1520	2024	2375	2510	2945	3490	4100
0,4	120	143	185	223	307	370	473	570	739	891	1250	1505	1890	2280	2960	3565	3630	4380	5050	6090
0,5	132	161	207	252	344	419	529	646	827	1009	1400	1705	2120	2585	3310	4035	4070	4970	5660	6910
0,6	147	182	230	284	383	472	590	728	923	1135	1560	1920	2360	2910	3690	4545	4470	5520	6220	7675
0,8	174	218	272	341	453	567	698	873	1090	1365	1840	2305	2790	3490	4360	5460	5240	6555	7280	9115
1	203	255	317	398	526	661	811	1019	1270	1590	2140	2690	3245	4075	5070	6370	6030	7575	8385	10530
1,5	272	344	425	538	707	894	1090	1378	1700	2150	2875	3640	4355	5510	6800	8610	8050	10195	11200	14180
2	305	388	477	607	792	1008	1220	1550	1900	2425	3220	4100	4880	6210	7625	9700	10125	12890	14080	17920
2,5	366	468	572	731	950	1215	1460	1870	2285	2925	3865	4945	5855	7490	9145	11700	11990	15330	16660	21300
3	424	544	662	850	1100	1410	1695	2175	2645	3400	4475	5750	6775	8700	10600	13600	13880	17840	19300	24800
4	535	692	837	1080	1390	1800	2140	2770	3350	4330	5650	7310	8570	11080	13400	17300	17550	22725	24400	31600
5	640	834	1000	1300	1665	2160	2565	3330	4000	5210	6770	8800	10260	13340	16000	20840	21000	27350	29250	38000
6	745	975	1165	1520	1940	2530	2990	3900	4665	6090	7890	10300	11950	15600	18650	24370	24500	31900	34050	44400
7	850	1115	1330	1745	2210	2900	3400	4465	5320	6970	9000	11790	13600	17860	21300	27900	27900	36600	38800	50900
8	957	1255	1495	1965	2485	3260	3820	5030	5980	7860	10100	13280	15300	20100	23900	31430	31350	41200	43600	57300
9	1060	1395	1660	2185	2755	3630	4245	5590	6630	8740	11200	14770	16950	22370	26500	34960	34800	45800	48400	63800
10	1165	1540	1820	2400	3025	3990	4665	6150	7290	9610	12300	16250	18650	24600	29150	38500	38250	50500	53200	70200
11	1270	1680	1985	2625	3300	4360	5080	6720	7940	10500	13400	17750	20300	26900	31750	42000	41600	55100	58000	76600
12	1375	1820	2150	2845	3570	4730	5500	7290	8590	11380	14500	19240	22000	29150	34350	45500	45100	59700	62700	83100
13	1480	1960	2310	3070	3840	5090	5920	7850	9250	12270	15600	20730	23650	31400	37000	49000	48500	64400	67500	89500
14	1580	2100	2475	3290	4110	5460	6340	8400	9900	13150	16700	22200	25350	33650	39600	52600	52000	69000	72300	96000
15	1690	2245	2640	3500	4385	5830	6760	8980	10550	14030	17800	23700	27000	35900	42200	56100	55400	73600	77000	102400
16	1790	2385	2800	3725	4655	6190	7170	9540	11200	14900	18950	25200	28700	38200	44800	59600	58800	78200	81800	108800
17	1900	2530	2965	3950	4930	6560	7590	10100	11850	15800	20050	26700	30350	40400	47400	63100	62200	82900	86600	115300
18	2000	2670	3130	4170	5200	6920	8010	10670	12500	16650	21150	28100	32050	42700	50100	66700	65700	87500	91400	121700
19	2100	2800	3295	4390	5470	7300	8430	11240	13150	17550	22250	29600	33700	44900	52700	70200	69100	92100	96200	128100
20	2210	2950	3460	4610	5750	7660	8850	11800	13800	18400	23350	31150	35400	47200	55300	73700	72600	96800	101000	134600
21	2320	3090	3620	4830	6020	8020	9250	12370	14500	19300	24500	32650	37100	49400	57900	77300	76000	101400	105800	141000
22	2420	3230	3790	5050	6290	8390	9700	12930	15150	20200	25600	34150	38800	51700	60600	80800	79500	106000	110900	147500
24	2635	3515	4120	5490	6840	9120	10500	14060	16450	21970	27850	37100	42100	56200	65900	87900	86500	115300	120600	160400
25	2740	3655	4280	5710	7120	9490	10950	14620	17100	22850	28950	38600	43800	58500			90200	120000	125500	166900
26	2850	3800	4450	5930	7390	9850	11350	15190	17800	23730	30050	40100					93700	124600	130300	173300
28	3060	4080	4780	6370	7950	10600	12250	16320	19100	25500	32300	43100								
30	3270	4360	5120	6810	8500	11320	13100	17450	20450	27250										
32	3490	4640	5450	7250	9060	12050	13950	18570	21800	29000										
34		4925		7700		12790		19700		30800										
40		5770																		

TÜV · SV · · · -663 · D/G
 Calculation acc. to TRD 421 and AD2000-A2
 DN125, DN150 higher pressures on request

Stainless steel version max. 24 bar for saturated steam.

Capacity water incl. 10% overpressure

	Gauge press.		Water 20°C (t/h)								
	bar	DN 20	DN 25	DN 32	DN 40	DN 50	DN 65	DN 80	DN 100	DN 125	DN 150
	0,2	3,28	5,13	8,53	13,1	20,5	30,8	46,7	73,0	94,9	132,0
	0,5	5,19	8,12	13,5	20,8	32,5	48,8	73,9	115,0	150,0	209,0
	1	7,35	11,5	19,1	29,4	45,9	69,0	104,0	163,0	212,0	295,0
	2	10,4	16,2	27,0	41,6	64,9	97,5	148,0	231,0	300,0	417,0
	3	12,7	19,9	33,0	50,9	79,5	119,0	181,0	283,0	368,0	511,0
	4	14,7	22,9	38,1	58,7	91,8	138,0	209,0	326,0	424,0	590,0
	5	16,4	25,7	42,6	65,5	102,0	154,0	233,0	365,0	474,0	660,0
	6	18,0	28,1	46,7	72,0	112,0	169,0	256,0	400,0	520,0	723,0
	7	19,4	30,4	50,4	77,7	121,0	182,0	276,0	432,0	562,0	781,0
	8	20,8	32,5	53,9	83,1	130,0	195,0	295,0	461,0	600,0	835,0
	9	22,0	34,4	57,2	88,1	138,0	207,0	313,0	490,0	637,0	885,0
	10	23,2	36,3	60,3	92,9	145,0	218,0	330,0	516,0	671,0	933,0
	11	24,4	38,0	63,2	97,4	152,0	229,0	346,0	540,0	703,0	977,0
	12	25,4	39,7	66,0	102,0	159,0	239,0	362,0	565,0	735,0	1022,0
	13	26,5	41,4	68,7	106,0	165,0	249,0	376,0	587,0	764,0	1062,0
	14	27,5	42,9	71,3	110,0	172,0	258,0	391,0	611,0	794,0	1104,0
	16	29,4	45,9	76,3	117,0	184,0	276,0	418,0	653,0	849,0	1181,0
	18	31,2	48,7	80,9	125,0	195,0	293,0	443,0	692,0	900,0	1252,0
	19	32,0	49,9	82,9	128,0	200,0	300,0	454,0	710,0	923,0	1284,0
max. set pressure stainless steel version ↓	20	32,8	51,3	85,3	131,0	205,0	308,0	467,0	730,0	949,0	1320,0
	21	33,7	52,6	87,4	135,0	210,0	316,0	479,0	748,0	973,0	1350,0
	24	36,0	56,2	93,4	144,0	225,0	338,0	512,0	800,0	1040,0	1443,0
	25	36,7	57,4	95,3	147,0	229,0	345,0	522,0		1059,0	1473,0
	26	37,4	58,5	97,2	150,0	234,0	352,0			1080,0	1502,0
	27	38,2	59,6	99,0	153,0	238,0	358,0			1100,0	
	28	38,9	60,7	101,0	155,0	243,0	365,0				
	30	40,2	62,9	104,0	161,0	251,0					
	32	41,5	64,8	108,0	166,0	259,0					
		34	42,8	66,9	111,0	171,0	268,0				
	40	46,4									

TÜV · SV · ... · 663 · F

Certified coefficient of discharge Kdr (Values for D/G variable: DN20-100 < 3,5 bar, DN125-150 < 4,0 bar)										
Kdr	DN 20	DN 25	DN 32	DN 40	DN 50	DN 65	DN 80	DN 100	DN 125	DN 150
D/G	0,74								0,7	
F	0,54					0,48			0,45	

ARI-SAFE - Heating-safety valve

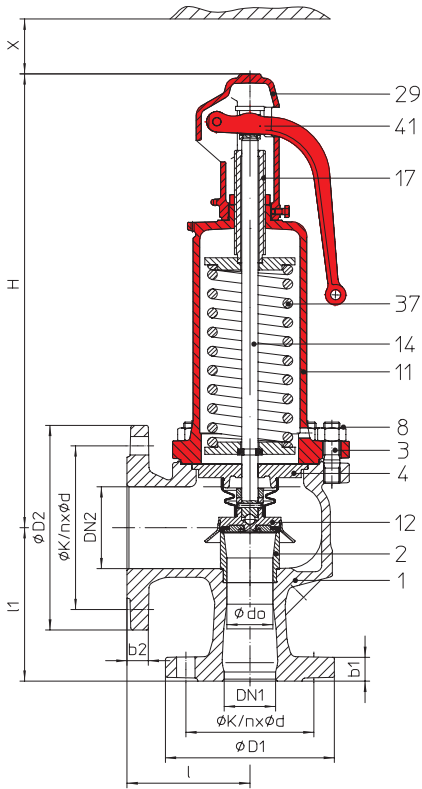

Fig. ... 903

Figure	Nominal pressure	Material	Nominal diameter
12.903	PN16/16	EN-JL1040	DN20/32 - 150/250
Figure	Temperature range	Flange	Flange holes/-thickness tolerances
12.903	-10°C to +120°C	DIN EN 1092-2	DIN 2533/2533

Type-test approval

spring loaded: TÜV · SV · · · -688 · D/G/H

Set gauge pressure refer to „Capacity“.

Requirement

Acc. to TRD 721 Part 6, material selection observe TRD!
(EN-JL1040 max. 10 bar; >10 bar 25.903 EN-JS1049 or 35.903 1.0619+N)

Application

Acc. to DIN EN 12828 Heating systems in buildings

Constructions

Standard safety valve, spring loaded, direct loaded metal seat with EPDM insert, EPDM-bellow, closed spring bonnet with control hole, open lifting device, stainless steel seat and spindle

Sizing

Acc. to TRD Part 6.2.5 (see capacity-tables Figure 903)

Order data:

ARI-SAFE-Safety valve,
Figure ..., DN .../..., PN ..., Material ..., Set gauge pressure ...bar

Selection of possible applications

Heating facilities
(other applications on request)

Selection of possible flow media

Warm water, hot water
(other flow media on request)

EPDM-disc, soft seal insert; EPDM-bellow

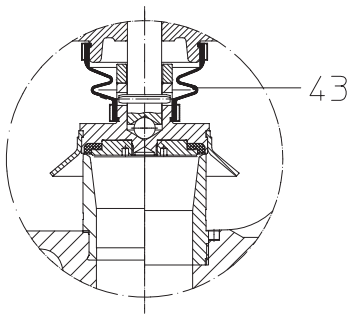

(Design DN 20 - 100) (Design DN 125 - 150)

Dimensions and weights

DN1/DN2	(mm)	20/32	25/40	32/50	40/65	50/80	65/100	80/125	100/150	125/200	150/250
d ₀	(mm)	18	22,5	29	36	45	58,5	72	90	106	125
l	(mm)	85	100	110	115	120	140	160	180	200	225
l ₁	(mm)	95	105	115	140	150	170	195	220	250	285
H	(mm)	270	280	330	390	435	545	610	690	845	890
X	(mm)	150	150	200	250	300	350	400	500	500	500
Drainhole with plug (optional)	(inch)	G 1/4"					G 3/8"				
Weight	(kg)	8,5	9,5	13,5	20	26	39	53	82	125	165

Standard-flange dimensions refer to page 34.

Spring ranges (barg)

DN20	DN25 - 50	DN65	DN80	DN100	DN125	DN150
0,2 - 0,5	0,2 - 0,5	0,2 - 0,5	0,2 - 0,5	0,2 - 0,5	0,2 - 0,4	0,2 - 0,5
0,52 - 1	0,52 - 1	0,52 - 1	0,52 - 1	0,52 - 1	0,42 - 0,75	0,52 - 1
1,05 - 1,5	1,05 - 1,5	1,05 - 1,5	1,05 - 1,5	1,05 - 1,5	0,77 - 1,1	1,05 - 1,5
1,55 - 2,5	1,55 - 2	1,55 - 2	1,55 - 2	1,55 - 2	1,15 - 1,5	1,55 - 1,9
2,55 - 4,5	2,05 - 2,7	2,05 - 2,7	2,05 - 2,7	2,05 - 2,5	1,55 - 1,9	1,95 - 2,3
4,6 - 8,5	2,75 - 3,6	2,75 - 3,6	2,75 - 3,6	2,55 - 3	1,95 - 2,5	2,35 - 2,7
8,6 - 16	3,7 - 5	3,7 - 5	3,7 - 5	3,05 - 3,6	2,55 - 2,95	2,75 - 3,3
	5,1 - 9	5,1 - 9	5,1 - 9	3,7 - 5	3 - 4	3,35 - 4,1
	9,1 - 16	9,1 - 16	9,1 - 14	5,1 - 9	4,1 - 5,7	4,2 - 5,5
			14,1 - 16	9,1 - 14	5,8 - 8,2	5,6 - 7,4
				14,1 - 16	8,3 - 12	7,5 - 11
					12,1 - 16	11,1 - 16

Parts

Pos.	Description	Fig. 12.903
1	Body	EN-GJL-250 , EN-JL1040
2	Seat	X20Cr13+QT, 1.4021+QT
3	Studs	25CrMo4, 1.7218
4	Spindle guide	X20Cr13+QT, 1.4021+QT
8	Hexagon nut	C35E, 1.1181
11	Bonnet, closed	EN-GJL-250 , EN-JL1040
12	Disc unit	X20Cr13+QT, 1.4021+QT / EPDM
14	Spindle *	X20Cr13+QT, 1.4021+QT
17	Adjusting screw	X20Cr13+QT, 1.4021+QT
29	Cap, open	EN-GJL-250 , EN-JL1040
37	Spring *	FDSiCr
41	Lever, open	EN-GJS-400-18U-LT, EN-JS1049
43	Bellow	EPDM

* Spare parts

Information / restriction of technical rules need to be observed!

ARI-Valves of EN-JL1040 are not allowed to be operated in systems acc. to TRD 110.

A production allowance acc. to TRB 801 No. 45 exists (acc. to TRB 801 No. 45 EN-JL1040 is not allowed.)

The engineer, designing a system or a plant, is responsible for the selection of the correct valve.

Capacity saturated steam incl. 10% overpressure

Set gauge pressure in bar	Capacity	Saturated steam (kg/h)						Heating capacity (kW)				
		Inlet diameter										
		DN 20	DN 25	DN 32	DN 40	DN 50	DN 65	DN 80	DN 100	DN 125	DN 150	
1,0	kg/h	203	317	526	811	1270	2140	3245	5070	6030	8385	
	kW	124	193	321	495	774	1310	1980	3095	3680	5120	
1,5	kg/h	272	425	707	1090	1700	2875	4355	6800	8050	11200	
	kW	164	257	427	658	1030	1740	2630	4110	4870	6770	
2,0	kg/h	305	477	792	1220	1900	3220	4880	7625	10125	14080	
	kW	183	285	474	731	1140	1930	2920	4570	6060	8430	
2,5	kg/h	366	572	950	1460	2285	3865	5855	9145	11990	16660	
	kW	217	340	565	870	1360	2300	3480	5440	7120	9900	
3,0	kg/h	424	662	1100	1695	2645	4475	6775	10600	13880	19300	
	kW	250	391	649	1000	1560	2640	4000	6250	8190	11400	
3,5	kg/h	482	754	1250	1930	3015	5100	7720	12050	15600	21700	
	kW	283	442	735	1130	1770	2990	4530	7070	9150	12700	
4,0	kg/h	535	837	1390	2140	3350	5650	8570	13400	17550	24400	
	kW	312	488	810	1250	1950	3300	5000	7800	10200	14200	
4,5	kg/h	588	920	1530	2355	3680	6215	9410	14710	19300	26850	
	kW	341	533	885	1360	2130	3600	5460	8520	11100	15600	
5,0	kg/h	640	1000	1665	2565	4000	6770	10260	16000	21000	29250	
	kW	370	578	960	1480	2310	3900	5910	9240	12100	16900	
5,5	kg/h	694	1085	1800	2775	4340	7330	11100	17350	22770	31660	
	kW	398	622	1030	1590	2490	4200	6370	9950	13000	18200	
6,0	kg/h	745	1165	1940	2990	4665	7890	11950	18650	24500	34050	
	kW	426	666	1100	1700	2660	4500	6820	10600	14000	19400	
6,5	kg/h	800	1250	2075	3200	4995	8440	12790	20000	26220	36450	
	kW	454	709	1180	1810	2840	4790	7260	11300	14900	20700	
7,0	kg/h	850	1330	2210	3400	5320	9000	13600	21300	27900	38800	
	kW	481	752	1250	1930	3000	5080	7700	12000	15800	22000	
7,5	kg/h	904	1415	2345	3615	5650	9550	14470	22600	29660	41250	
	kW	509	795	1320	2030	3180	5370	8140	12700	16700	23200	
8,0	kg/h	957	1495	2485	3820	5980	10100	15300	23900	31350	43600	
	kW	536	837	1390	2140	3350	5660	8580	13400	17600	24500	
9,0	kg/h	1060	1660	2755	4245	6630	11200	16950	26500	34800	48400	
	kW	590	921	1530	2360	3685	6230	9435	14740	19340	26900	
10,0	kg/h	1165	1820	3025	4665	7290	12300	18650	29150	38250	53200	
	kW	643	1000	1670	2570	4010	6790	10300	16000	21100	29300	
11,0	kg/h	1270	1985	3300	5080	7940	13400	20300	31750	41600	58000	
	kW	695	1085	1800	2780	4340	7340	11100	17400	22800	31700	
12,0	kg/h	1375	2150	3570	5500	8590	14500	22000	34350	45100	62700	
	kW	745	1165	1940	2990	4670	7890	12000	18700	24500	34000	
13,0	kg/h	1480	2310	3840	5920	9250	15600	23650	37000	48500	67500	
	kW	798	1250	2070	3190	4990	8430	12800	20000	26200	36400	
14,0	kg/h	1580	2475	4110	6340	9900	16700	25350	39600	52000	72300	
	kW	850	1325	2200	3390	5300	8970	13600	21200	27900	38700	
15,0	kg/h	1690	2640	4385	6760	10550	17800	27000	42200	55400	77000	
	kW	900	1405	2330	3590	5620	9500	14400	22500	29500	41000	
16,0	kg/h	1790	2800	4655	7170	11200	18950	28700	44800	58800	81800	
	kW	950	1480	2460	3790	5930	10000	15200	23700	31100	43300	

Calculated acc. to TRD 721 Part 6 and AD2000-A2

Capacity water

Set gauge pressure in bar	Water 20°C (kg/h)	
	DN 20	DN 25
1	7300	11500
2	10400	16000
3	12700	20000
4	14700	23000
5	16400	25500
6	18000	28000
7	19400	30500
8	21000	32500
9	22000	34500
10	23000	36500
11	24500	38000
12	25500	40000
13	26500	41500
14	27500	42500
15	28000	44000
16	29500	46000

Sizing: 1 l/h Δ 1 kW
 Sizing safety valves for the volume flow of water expansion
 (DIN 4751 p2 - item 8.1)

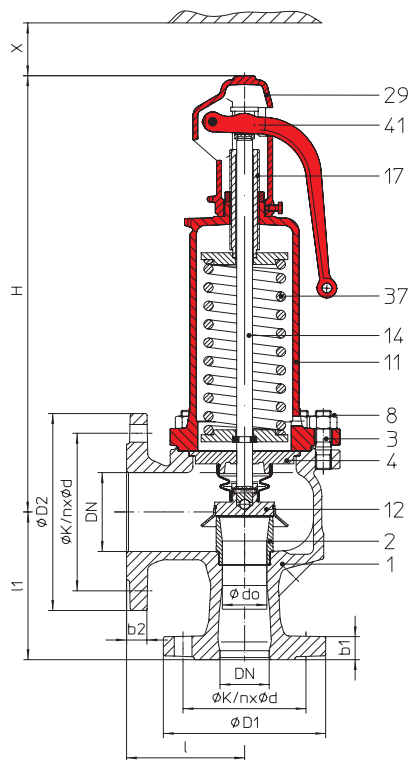
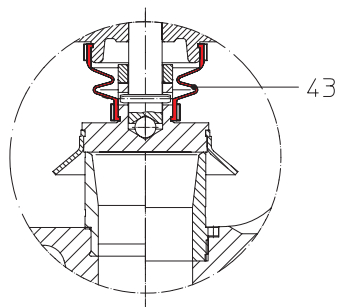
ARI-SAFE - Low pressure steam - safety valve

Fig. ... 904
**Metal seal;
EPDM-bellow**

(Design DN 20 - 100) (Design DN 125 - 150)

Figure	Nominal pressure	Material	Nominal diameter
12.904	PN16/16	EN-JL1040	DN20/32 - 150/250
Figure	Temperature range	Flange	Flange holes/-thickness tolerances
12.904	-10°C to +120°C	DIN EN 1092-2	DIN 2533/2533
Type-test approval			
Low pressure steam - safety valve: TÜV · SV · . . -688 · D			
Set gauge pressure refer to „Capacity“.			
Requirement			
Acc. to TRD 721 Part 5			
Application			
For low pressure steamgenerators up to 1 bar, DIN 4750 and DIN EN 12828 Heating systems in buildings			
Construction			
Standard safety valve, spring loaded, direct loaded, EPDM-bellow, closed bonnet with control hole, open lifting device, stainless steel seat and spindle			
Sizing			
refer to „Capacity“.			
Order data:			
ARI-SAFE-Safety valve, Figure ..., DN .../..., PN ..., Material ..., Set gauge pressure ...bar			

Selection of possible applications

Heating facilities

(other applications on request)

Selection of possible flow media

Steam

(other flow media on request)

Dimensions and weights

DN	(mm)	20/32	25/40	32/50	40/65	50/80	65/100	80/125	100/150	125/200	150/250
d_0	(mm)	18	22,5	29	36	45	58,5	72	90	106	125
l	(mm)	85	100	110	115	120	140	160	180	200	225
l_1	(mm)	95	105	115	140	150	170	195	220	250	285
H	(mm)	270	280	330	390	435	545	610	690	845	890
X	(mm)	150	150	200	250	300	350	400	500	500	500
Drainhole with plug (optional)	(inch)	G 1/4"					G 3/8"				
Weight	(kg)	8,5	9,5	13,5	20	26	39	53	82	125	165

Standard-flange dimensions refer to page 34.

Capacity Saturated steam

Set gauge pressure in bar	Capacity	Saturated steam (kg/h)									
		Inlet diameter									
		DN 20	DN 25	DN 32	DN 40	DN 50	DN 65	DN 80	DN 100	DN 125	DN 150
0,2	kg/h	72	113	187	289	451	763	1155	1805	2241	3116
0,3	kg/h	92	144	239	368	575	972	1472	2300	2867	3986
0,4	kg/h	110	172	286	440	688	1163	1762	2753	3380	4700
0,5	kg/h	125	196	325	501	783	1325	2006	3135	3858	5365
0,6	kg/h	142	223	370	569	889	1503	2277	3557	4317	6004
0,7	kg/h	158	248	412	634	990	1675	2537	3964	4748	6603
0,8	kg/h	173	271	450	693	1082	1830	2772	4331	5201	7233
0,9	kg/h	179	292	485	746	1166	1971	2986	4666	5616	7809
1,0	kg/h	203	317	526	811	1270	2140	3245	5070	6030	8385

Conversion rates: 1 kW = 860 kcal/h* = 0,86 Mcal/h* = 3,6 MJ/h * not lawful units
 1 Mcal/h* = 1000 kcal/h* = 1,163 kW

Parts

Pos.	Description	Fig. 12.904
1	Body	EN-GJL-250 , EN-JL1040
2	Seat	X6CrNiMoTi17-12-2, 1.4571
3	Studs	25CrMo4, 1.7218
4	Spindle guide	X20Cr13+QT, 1.4021+QT
8	Hexagon nut	C35E, 1.1181
11	Bonnet, closed	EN-GJL-250 , EN-JL1040
12	Disc unit	X39CrMo17-1+QT, 1.4122+QT
14	Spindle *	X20Cr13+QT, 1.4021+QT
17	Adjusting screw	X20Cr13+QT, 1.4021+QT
29	Cap, open	EN-GJL-250 , EN-JL1040
37	Spring *	FDSiCr
41	Lever, open	EN-GJS-400-18U-LT, EN-JS1049
43	Bellow	EPDM

* Spare parts

Information / restriction of technical rules need to be observed!

ARI-Valves of EN-JL1040 are not allowed to be operated in systems acc. to TRD 110.

A production allowance acc. to TRB 801 No. 45 exists (acc. to TRB 801 No. 45 EN-JL1040 is not allowed.)

The engineer, designing a system or a plant, is responsible for the selection of the correct valve.

ARI-SAFE-P - Standard safety valve D/G/F

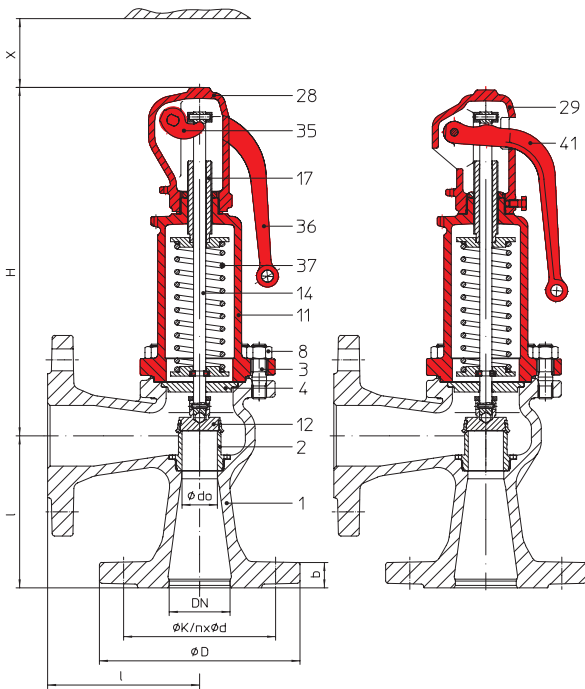

Fig. ... 921
closed lifting device

Fig. ... 922
open lifting device

Figure	Nominal pressure	Material	Nominal diameter
12.921 / 922 / 923 / 924	PN16	EN-JL1040	DN20 - 100
35.921 / 922 / 923 / 924	PN40	1.0619+N	DN20 - 100
55.921 / 923	PN40	1.4408	DN20 - 100
Figure	Temperature range	Flange	Flange holes/- thickness tolerances
12.921 / 922 / 923 / 924	-10°C to +300°C	DIN EN 1092-2	DIN 2533
35.921 / 922 / 923 / 924	-10°C to +450°C	DIN EN 1092-1	DIN 2545
55.921 / 923	-60°C to +400°C	DIN EN 1092-1	DIN 2545

Type-test approval

Standard safety valve: TÜV · SV ... -811 · D/G (Fig. 921/922/923/924)

Standard safety valve: TÜV · SV ... -811 · F (Fig. 921/923)

Set gauge pressure refer to „Capacity“.

Requirement

Acc. to EN ISO 4126-1, VdTÜV-leaflet 100, AD2000-A2, TRD 421, material selection observe TRB 801 No. 45!

Construction

Safety valve, spring loaded, direct loaded

Sizing

For steam, air and water see capacity tables, calculation acc. to EN ISO 4126-1, TRD 421 and AD2000-A2.

Details required

- Medium gasform: Mass flow (kg/h), molar mass (kg/kmol), temperature (°C), set gauge pressure (bar), back gauge pressure (bar)
- Medium liquid: Mass flow (kg/h), density (kg/m³), viscosity, temperature (°C), set gauge pressure (bar), back gauge pressure (bar)

Order data:

ARI-SAFE-P - Safety valve,
Figure, DN ..., PN .., Material, Set gauge pressure bar

Selection of possible applications

Chemical Industry, processing industry, plant manufacturing
(other applications on request)

Selection of possible flow media

EN-JL1040, 1.0619+N: Steam, neutral gases, vapours and liquids

1.4408: Steam, aggressive gases, vapours and liquids

(other flow media on request)

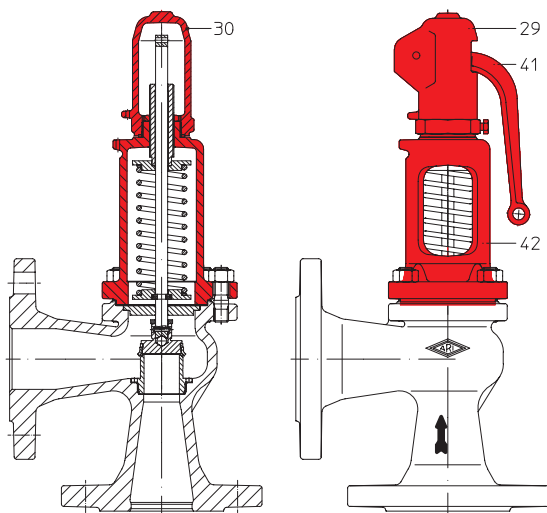

Fig. ... 923
gastight cap

Fig. ... 924
open lifting device

	without metal bellow	with metal bellow
Superimposed back pressure	no backpressure allowed	on request
Built up back pressure	max. 10% from set pressure (gauge) (higher on request)	on request

Dimensions and weights

DN	(mm)	20	25	32	40	50	65	80	100
d ₀	(mm)	12	15	18	20	29	36	44	55
A ₀	(mm ²)	113	177	254	314	661	1018	1520	2376
l	(mm)	95	100	105	115	125	145	155	175
H	(mm)	260	270	285	290	290	340	400	450
H (Bellow design)	(mm)	285	300	325	330	345	400	455	515
X	(mm)	130	130	150	150	150	200	250	300
Weight	(kg)	5	5,5	8	9,5	11,5	15,5	20,5	33
Weight (Bellow design)	(kg)	5,4	6	9	10,5	12,8	17,5	23	37

Standard-flange dimensions refer to page 34.

Spring ranges: Standard design (barg)

DN20	DN25	DN32	DN40	DN50	DN65	DN80	DN100
0,3 - 0,5	0,2 - 0,6	0,2 - 0,55	0,2 - 0,4	0,2 - 0,4	0,2 - 0,5	0,2 - 0,6	0,2 - 0,5
0,52 - 1,0	0,62 - 1,1	0,57 - 0,8	0,42 - 0,6	0,42 - 0,6	0,52 - 1,2	0,62 - 1,2	0,52 - 1,1
1,05 - 1,4	1,15 - 2,0	0,82 - 1,2	0,62 - 1,1	0,62 - 1,2	1,25 - 2,0	1,25 - 2,1	1,15 - 1,7
1,45 - 1,9	2,05 - 2,7	1,25 - 2,0	1,15 - 1,8	1,25 - 1,8	2,05 - 2,7	2,15 - 2,6	1,75 - 2,4
1,95 - 2,5	2,75 - 3,7	2,05 - 3,3	1,85 - 2,7	1,85 - 2,5	2,75 - 3,4	2,65 - 3,2	2,45 - 3,1
2,55 - 3,5	3,8 - 5,0	3,35 - 5,2	2,75 - 4,3	2,55 - 3,2	3,45 - 4,5	3,25 - 4,2	3,15 - 4,0
3,55 - 4,0	5,1 - 8,0	5,3 - 8,0	4,4 - 6,0	3,25 - 4,5	4,6 - 5,5	4,3 - 5,5	4,1 - 5,0
4,1 - 5,5	8,1 - 10,5	8,1 - 11,5	6,1 - 9,0	4,6 - 8,5	5,6 - 6,8	5,6 - 6,5	5,1 - 8,0
5,6 - 7,0	10,6 - 15,0	11,6 - 16,5	9,1 - 12,0	8,6 - 13,0	6,9 - 8,5	6,6 - 9,0	8,1 - 11,0
7,1 - 10,5	15,1 - 23,0	16,6 - 22,0	12,1 - 17,0	13,1 - 17,0	8,6 - 14,0	9,1 - 12,0	11,1 - 17,5
10,6 - 17,0	23,1 - 35,0	22,1 - 30,0	17,1 - 30,0	17,1 - 23,0	14,1 - 23,0	12,1 - 16,5	17,6 - 27,5
17,1 - 25,0	35,1 - 40,0	30,1 - 40,0	30,1 - 40,0	23,1 - 34,0	23,1 - 34,0	16,6 - 20,0	27,6 - 40,0
25,1 - 37,0				34,1 - 40,0	34,1 - 40,0	20,1 - 33,0	
37,1 - 40,0						33,1 - 40,0	

Spring ranges: Bellow design (barg)

DN20	DN25	DN32	DN40	DN50	DN65	DN80	DN100
3,0 - 5,5	3,0 - 4,8	3,0 - 4,5	3,0 - 4,5	3,0 - 3,5	3,0 - 3,5	3,0 - 3,5	3,0 - 4,5
5,6 - 8,0	4,9 - 6,0	4,6 - 8,0	4,6 - 5,7	3,6 - 5,0	3,6 - 4,3	3,6 - 4,9	4,6 - 6,5
8,1 - 12,0	6,1 - 8,0	8,1 - 11,0	5,8 - 10,0	5,1 - 7,0	4,4 - 5,9	5,0 - 7,0	6,6 - 10,0
12,1 - 21,0	8,1 - 12,5	11,1 - 14,5	10,1 - 16,0	7,1 - 10,5	6,0 - 7,5	7,1 - 9,0	10,1 - 18,0
21,1 - 27,5	12,6 - 16,0	14,6 - 21,0	16,1 - 22,0	10,6 - 15,5	7,6 - 8,8	9,1 - 11,0	18,1 - 35,0
27,6 - 40,0	16,1 - 20,5	21,1 - 40,0	22,1 - 31,0	15,6 - 20,0	8,9 - 14,0	11,1 - 14,7	
	20,6 - 30,0		31,1 - 40,0	20,1 - 40,0	14,1 - 21,0	14,8 - 18,8	
	30,1 - 40,0				21,1 - 30,0	18,9 - 35,0	
					30,1 - 40,0		

Design with bellow as standard valve (only Fig. 921/923)

Parts

Pos.	Description	Fig. 12.921/922/923/924	Fig. 35.921/922/923/924	Fig. 55.921/922
1	Body	EN-GJL-250 , EN-JL1040	GP240GH+N, 1.0619+N	GX5CrNiMo19-11-2, 1.4408
2	Seat	X6CrNiMoTi17-12-2, 1.4571		
3	Studs	25CrMo4, 1.7218		A4 - 70
4	Spindle guide	X20Cr13+QT, 1.4021+QT		X6CrNiMoTi17-12-2, 1.4571
8	Hexagon nut	C35E, 1.1181		A4
11	Bonnet, closed	EN-GJL-250 , EN-JL1040	EN-GJS-400-18U-LT, EN-JS1049	GX5CrNiMo19-11-2, 1.4408
12	Disc unit	X39CrMo17-1+QT, 1.4122+QT		X6CrNiMoTi17-12-2, 1.4571
14	Spindle *	X20Cr13+QT, 1.4021+QT		X6CrNiMoTi17-12-2, 1.4571
17	Adjusting screw	X20Cr13+QT, 1.4021+QT		X6CrNiMoTi17-12-2, 1.4571
28	Cap, closed	EN-GJL-250 , EN-JL1040	EN-GJS-400-18U-LT, EN-JS1049	GX5CrNiMo19-11-2, 1.4408
29	Cap, open	EN-GJL-250 , EN-JL1040	EN-GJS-400-18U-LT, EN-JS1049	GX5CrNiMo19-11-2, 1.4408
30	Cap, gastight	EN-GJL-250 , EN-JL1040	EN-GJS-400-18U-LT, EN-JS1049	GX5CrNiMo19-11-2, 1.4408
35	Lift fork	EN-GJS-400-18U-LT, EN-JS1049		GX5CrNiMo19-11-2, 1.4408
36	Lever, closed	EN-GJS-400-18U-LT, EN-JS1049		X6CrNiMoTi17-12-2, 1.4571
37	Spring *	FDSiCr		X10CrNi18-8, 1.4310
41	Lever, open	EN-GJS-400-18U-LT, EN-JS1049		--
42	Bonnet, open	EN-GJL-250 , EN-JL1040	EN-GJS-400-18U-LT, EN-JS1049	--
43	Bellow (optional)	EPDM		
55	Bellow unit (optional)	X6CrNiMoTi17-12-2, 1.4571		
70	Balanced piston (optional)	X6CrNiMoTi17-12-2, 1.4571		

* Spare parts

Information / restriction of technical rules need to be observed!

ARI-Valves of EN-JL1040 are not allowed to be operated in systems acc. to TRD 110.

A production allowance acc. to TRB 801 No. 45 exists (acc. to TRB 801 No. 45 EN-JL1040 is not allowed.)

The engineer, designing a system or a plant, is responsible for the selection of the correct valve.

Capacity saturated steam / air incl. 10% overpressure

Set gauge pressure bar	I Saturated steam (kg/h)				II Air 0°C and 1.013 bara (Nm³/h)											
	DN 20		DN 25		DN 32		DN 40		DN 50		DN 65		DN 80		DN 100	
	I	II	I	II	I	II	I	II	I	II	I	II	I	II	I	II
0,2 ¹⁾	20	24	23	27	33	38	44	51	85	100	142	167	195	229	305	358
0,4	23	28	34	41	48	58	65	78	126	152	209	252	290	349	450	546
0,5	27	32	39	47	55	68	74	90	144	176	239	292	332	405	520	632
0,6	30	37	43	53	62	77	82	102	162	199	267	330	372	459	580	717
0,8	36	45	51	63	73	91	100	125	189	237	323	404	435	545	680	852
1	41	52	58	73	84	106	114	144	218	274	370	466	500	631	785	986
2	68	86	97	123	139	178	188	240	362	461	610	777	830	1061	1300	1657
3	95	123	137	176	197	253	265	340	510	658	860	1103	1180	1514	1840	2365
4	119	154	171	221	246	318	330	428	640	826	1070	1385	1470	1902	2300	2970
5	142	185	205	266	295	383	396	515	765	995	1280	1665	1760	2290	2750	3580
6	166	217	238	311	343	448	460	602	890	1165	1495	1950	2050	2680	3200	4180
7	189	248	272	356	391	513	525	689	1015	1330	1700	2230	2340	3065	3650	4790
8	213	279	305	401	440	577	590	776	1140	1500	1910	2515	2630	3450	4100	5390
9	236	311	340	446	490	642	655	863	1265	1670	2120	2800	2910	3840	4550	6000
10	259	342	370	491	535	707	720	950	1390	1835	2330	3080	3200	4225	5000	6600
12	306	405	440	581	630	837	850	1125	1640	2170	2750	3645	3780	5000	5900	7800
14	352	468	505	671	730	967	980	1300	1890	2510	3170	4200	4350	5780	6800	9000
16	400	530	570	761	825	1096	1105	1475	2140	2845	3590	4770	4920	6550	7700	10200
18	445	593	640	851	920	1226	1235	1645	2390	3180	4000	5340	5500	7320	8600	11450
20	490	656	705	941	1020	1356	1365	1820	2640	3520	4430	5900	6080	8100	9500	12650
22	540	718	770	1031	1110	1485	1495	1995	2890	3855	4850	6465	6660	8870	10400	13850
24	585	781	840	1121	1210	1615	1630	2170	3140	4190	5270	7030	7240	9650	11300	15100
25	609	812	875	1167	1260	1680	1690	2250	3270	4360	5480	7310	7530	10040	11760	15680
26	630	844	910	1211	1310	1745	1760	2340	3400	4530	5700	7595	7820	10400	12200	16300
28	680	907	975	1302	1405	1875	1890	2520	3650	4860	6120	8160	8400	11200	13100	17500
30	730	969	1045	1390	1505	2000	2020	2690	3900	5200	6550	8720	8990	12000	14000	18700
32	775	1032	1110	1480	1600	2130	2150	2870	4160	5540	6980	9290	9580	12750	15000	19900
35		1126		1620		2330		3130		6040		10130		13900		21700
36		1155		1665		2390		3215		6220		10420		14300		22360
40		1283		1840		2650		3560		6880		11500		15850		24700

Stainless steel version max. 24 bar for saturated steam.

¹⁾ DN20 - 0,3 bar

Capacity water incl. 10% overpressure

	Gauge press.		Water 20°C (t/h)						
	bar	DN 20	DN 25	DN 32	DN 40	DN 50	DN 65	DN 80	DN 100
	0,2 ¹⁾	0,86	0,97	1,4	1,95	3,63	6,33	8,36	13,06
	0,5	1,11	1,54	2,21	3,09	5,74	10,0	13,22	20,6
	1	1,57	2,17	3,13	4,37	8,12	14,15	18,69	29,2
	2	2,22	3,07	4,42	6,17	11,48	20,0	26,4	41,3
	3	2,72	3,76	5,42	7,56	14,07	24,5	32,4	50,6
	4	3,14	4,35	6,26	8,73	16,24	28,3	37,4	58,4
	5	3,51	4,86	7,0	9,76	18,16	31,6	41,8	65,3
	6	3,85	5,32	7,66	10,69	19,89	34,6	45,8	71,6
	7	4,16	5,75	8,28	11,55	21,5	37,4	49,5	77,3
	8	4,45	6,14	8,85	12,35	23,0	40,0	52,9	82,6
	9	4,72	6,52	9,39	13,1	24,4	42,4	56,1	87,6
	10	4,97	6,87	9,89	13,81	25,7	44,7	59,1	92,4
	12	5,44	7,53	10,84	15,12	28,1	49,0	64,8	100,2
	14	5,88	8,13	11,71	16,34	30,4	52,9	69,9	109,3
	16	6,29	8,69	12,51	17,46	32,5	56,6	74,8	116,8
	18	6,67	9,22	13,27	18,52	34,4	60,0	79,3	123,9
	20	7,03	9,72	14,0	19,53	36,3	63,3	83,6	130,6
	22	7,37	10,19	14,7	20,5	38,1	66,3	87,7	137,0
	24	7,7	10,64	15,33	21,4	39,8	69,3	91,6	143,1
	25	7,86	10,86	15,64	21,8	40,6	70,7	93,3	146,0
	26	8,0	11,06	15,92	22,2	41,3	72,0	95,1	148,6
	28	8,3	11,47	16,52	23,1	42,9	74,7	98,7	154,2
	30	8,6	11,88	17,1	23,9	44,4	77,3	102,2	159,7
	35	9,28	12,83	18,47	25,8	47,9	83,5	110,4	172,5
	36	9,4	13,0	18,7	26,1	48,7	84,7	111,9	174,9
	40	9,92	13,71	19,75	27,6	51,3	89,3	118,0	184,4

¹⁾ DN20 - 0,3 bar

Certified coefficient of discharge Kdr (Values for D/G variable: < 3 bar)								
Kdr	DN 20	DN 25	DN 32	DN 40	DN 50	DN 65	DN 80	DN 100
D/G	0,37	0,34		0,37	0,34	0,37	0,34	
F	0,26	0,23		0,26	0,23	0,26	0,23	

ARI-SAFE-TC - Full lift safety valve D/G, Standard safety valve F

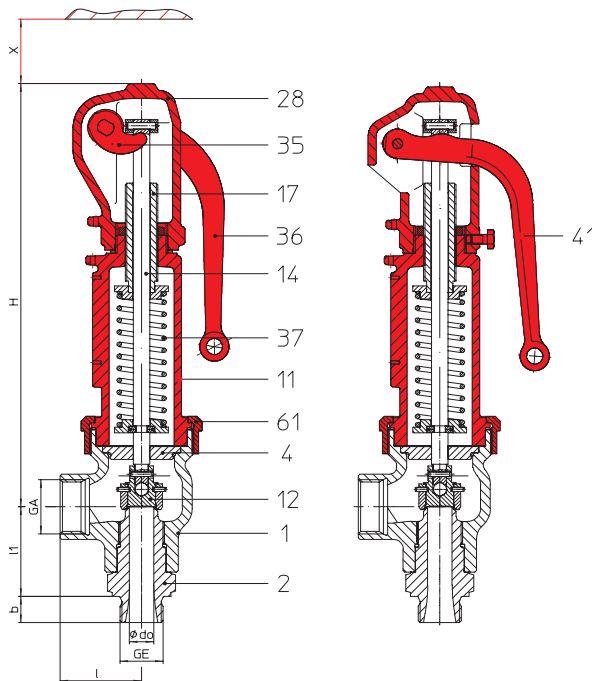

Fig. ... 941
closed lifting device closed
bonnet

Fig. ... 942
open lifting device open bonnet

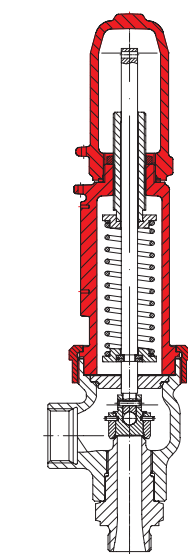

Fig. ... 943
gastight cap closed bonnet

Figure	Nominal pressure	Material	Nominal diameter
25.941 / 942 / 943	PN40	EN-JS1049	DN15 - 25
55.941 / 943	PN40	1.4408	DN15 - 25
Figure	Temperature range	Thread	
25.941 / 942 / 943	-10°C to +350°C	DIN ISO 228 Part 1	
55.941 / 943	-60°C to +400°C	DIN ISO 228 Part 1	
Type-test approval			
Full lift safety valve: TÜV · SV ... -995 · D/G (Fig. 941/942/943)			
Standard safety valve: TÜV · SV ... -995 · F (Fig. 941/943)			
Set gauge pressure refer to „Capacity“.			
Requirement			
Acc. to EN ISO 4126-1, VdTÜV-leaflet 100, AD2000-A2, TRD 421			
Construction			
Safety valve, spring loaded, direct loaded			
Sizing			
For steam, air and water see capacity tables, calculation acc. to EN ISO 4126-1, TRD 421 and AD2000-A2.			
Details required			
<ul style="list-style-type: none"> • Medium gasform: Mass flow (kg/h), molar mass (kg/kmol), temperature (°C), set gauge pressure (bar), back gauge pressure (bar) • Medium liquid: Mass flow (kg/h), density (kg/m³), viscosity, temperature (°C), Set gauge pressure (bar), back gauge pressure (bar) 			
Order data:			
ARI-SAFE-TC - Safety valve, Figure, DN ... / ..., PN .. / .., Material, Set gauge pressure bar			

Selection of possible applications

Chemical Industry, processing industry, plant manufacturing
(other applications on request)

Selection of possible flow media

EN-JL1040, 1.0619+N: Steam, neutral gases, vapours and liquids
1.4408: Steam, aggressive gases, vapours and liquids
(other flow media on request)

	without metal bellow	with metal bellow
Superimposed back pressure	no backpressure allowed	on request
Built up back pressure	max. 10% from set pressure (gauge) (higher on request)	on request

Dimensions and weights

DN	(mm)	15	20	25	25
G	(inch)	1/2" x 3/4"	3/4" x 1"	1" x 1 1/4"	1" x 1 1/2"
d ₀	(mm)	12	15	18	18
GE	(inch)	1/2"	3/4"	1"	1"
GA	(inch)	3/4"	1"	1 1/4"	1 1/2"
b	(mm)	15	16	18	18
l	(mm)	50	50	50	50
l1	(mm)	53	55	58	58
H	(mm)	260	260	260	260
H (Bellow design)	(mm)	295	295	300	300
X	(mm)	120	120	120	120
Weight	(kg)	3,5	3,5	3,8	3,8
Weight (Bellow design)	(kg)	4,4	4,4	4,7	4,7

Spring ranges: Standard design (barg)

DN15	DN20	DN25
0,3 - 0,6	0,3 - 0,48	0,2 - 0,4
0,62 - 0,9	0,5 - 0,68	0,42 - 0,88
0,92 - 1,35	0,7 - 1,35	0,9 - 1,5
1,4 - 2,2	1,4 - 2,1	1,55 - 2,1
2,25 - 3,3	2,15 - 3	2,15 - 2,6
3,35 - 4,5	3,05 - 4	2,65 - 3,2
4,6 - 5,5	4,1 - 5,5	3,25 - 4,2
5,6 - 6,7	5,6 - 7,7	4,3 - 6,2
6,8 - 8,2	7,8 - 11,4	6,3 - 8
8,3 - 11	11,5 - 15	8,1 - 10
11,1 - 13	15,1 - 20	10,1 - 15,5
13,1 - 18,5	20,1 - 28	15,6 - 18
18,6 - 32,4	28,1 - 35	18,1 - 29,9
32,5 - 40	35,1 - 40	30 - 40

Spring ranges: Bellow design (barg)

DN15	DN20	DN25
5,7 - 6,5	4 - 5,7	4 - 5,4
6,6 - 8	5,8 - 7	5,5 - 6,4
8,1 - 9,3	7,1 - 9,9	6,5 - 7,4
9,4 - 11	10 - 14	7,5 - 8,4
11,1 - 15	14,1 - 21	8,5 - 10,4
15,1 - 19	21,1 - 28,9	10,5 - 13,4
19,1 - 29	29 - 40	13,5 - 16,4
29,1 - 40		16,5 - 20,4
		20,5 - 28

Design with bellow as standard valve (only Fig. 941/943)

Parts

Pos.	Description	Fig. 25.941/942/943	Fig. 55.941/943
1	Body	EN-GJS-400-18U-LT, EN-JS1049	GX5CrNiMo19-11-2, 1.4408
2	Screwed seat	X6CrNiMoTi17-12-2, 1.4571	
4	Spindle guide	X20Cr13+QT, 1.4021+QT	
11	Bonnet, closed	EN-GJS-400-18U-LT, EN-JS1049	GX5CrNiMo19-11-2, 1.4408
12	Disc unit	X39CrMo17-1+QT, 1.4122+QT	X6CrNiMoTi17-12-2, 1.4571
14	Spindle *	X20Cr13+QT, 1.4021+QT	X6CrNiMoTi17-12-2, 1.4571
17	Adjusting screw	X20Cr13+QT, 1.4021+QT	X6CrNiMoTi17-12-2, 1.4571
28	Cap, closed	EN-GJS-400-18U-LT, EN-JS1049	GX5CrNiMo19-11-2, 1.4408
35	Lift fork	EN-GJS-400-18U-LT, EN-JS1049	GX5CrNiMo19-11-2, 1.4408
36	Lever, closed	EN-GJS-400-18U-LT, EN-JS1049	
37	Spring *	51CrV4, 1.8159	X10CrNi18-8, 1.4310
41	Lever, open	EN-GJS-400-18U-LT, EN-JS1049	--
43	Bellow (optional)	EPDM	
55	Bellow unit (optional)	X6CrNiMoTi17-12-2, 1.4571	
61	Coupling	X6CrNiMoTi17-12-2, 1.4571	
70	Balanced piston (optional)	X6CrNiMoTi17-12-2, 1.4571	

* Spare parts

Information / restriction of technical rules need to be observed!

ARI-Valves of EN-JL1040 are not allowed to be operated in systems acc. to TRD 110.

A production allowance acc. to TRB 801 No. 45 exists (acc. to TRB 801 No. 45 EN-JL1040 is not allowed.)

The engineer, designing a system or a plant, is responsible for the selection of the correct valve.

Capacity saturated steam / air / water incl. 10% overpressure

Set gauge pressure				I Saturated steam (kg/h)			II Air 0°C and 1.013 bara (Nm ³ /h)			III Water 20°C (t/h)		
bar	DN 15			DN 20			DN 25			DN 25		
	Inlet Male	G1/2"		G3/4"			G1"			G1"		
	Outlet Female	G3/4"		G1"			G1 1/4"			G1 1/2"		
	do (mm)	12		15			18			18		
	I	II	III	I	II	III	I	II	III	I	II	III
0,2							75	88	3,22	75	88	3,22
0,3	35	41	1,49	47	56	2,17	94	112	3,94	94	112	3,94
0,5	46	57	1,92	65	79	2,80	124	151	5,10	124	151	5,10
1	72	91	2,72	103	129	3,96	188	237	7,19	188	237	7,19
2	120	153	3,85	172	219	5,60	320	405	10,17	320	405	10,17
3	162	209	4,71	238	305	6,86	430	552	12,46	430	552	12,46
4	206	266	5,44	300	390	7,92	545	702	14,39	545	702	14,39
5	246	320	6,08	360	469	8,85	650	845	16,10	650	845	16,10
6	285	375	6,66	420	549	9,70	755	988	17,62	755	988	17,62
7	325	429	7,20	480	628	10,47	860	1130	19,04	860	1130	19,04
8	370	483	7,69	540	708	11,20	970	1275	20,30	970	1275	20,30
9	410	537	8,16	600	787	11,88	1075	1415	21,60	1075	1415	21,60
10	450	592	8,60	655	867	12,52	1180	1560	22,70	1180	1560	22,70
11	490	646	9,02	715	946	13,13	1290	1705	23,80	1290	1705	23,80
12	530	700	9,42	775	1026	13,72	1395	1845	24,90	1395	1845	24,90
13	570	754	9,81	835	1105	14,27	1500	1990	25,90	1500	1990	25,90
14	610	809	10,18	890	1185	14,81	1605	2130	26,90	1605	2130	26,90
15	650	863	10,54	950	1265	15,33	1710	2275	27,90	1710	2275	27,90
16	690	917	10,88	1010	1345	15,84	1820	2420	28,80	1820	2420	28,80
17	730	971	11,22	1070	1420	16,32	1925	2560	29,70	1925	2560	29,70
18	770	1025	11,54	1130	1500	16,80	2030	2705	30,50	2030	2705	30,50
19	810	1080	11,86	1190	1580	17,26	2135	2850	31,40	2135	2850	31,40
20	850	1135	12,17	1245	1660	17,71	2245	2990	32,20	2245	2990	32,20
22	930	1240	12,76	1365	1820	18,57	2455	3275	33,70	2455	3275	33,70
24	1015	1350	13,33	1485	1980	19,40	2670	3560	35,20	2670	3560	35,20
26	1095	1460	13,87	1600	2140	20,20	2885	3850	36,70	2885	3850	36,70
28	1175	1570	14,40	1725	2300	20,90	3100	4135	38,10	3100	4135	38,10
30	1260	1675	14,90	1845	2455	21,70	3320	4420	39,40	3320	4420	39,40
32	1340	1785	15,39	1965	2615	22,40	3535	4705	40,70	3535	4705	40,70
34		1895	15,86		2775	23,10		4990	41,90		4990	41,90
36		2000	16,28		2940	23,8		5270	43,1		5270	43,1
40		2220	17,21		3250	25,00		5850	45,50		5850	45,50

Stainless steel version max. 24 bar for saturated steam.

Certified coefficient of discharge Kdr (Values for D/G variable: < 3,5 bar)			
Kdr	15	20	25
D/G	0,64	0,60	0,75
F	0,45	0,42	0,53

ARI-SAFE-TC - Heating-safety valve 945, Low pressure steam - safety valve 946

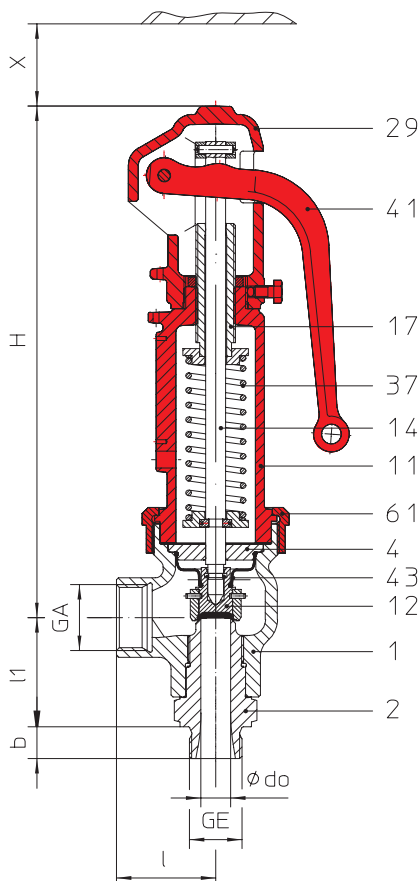

Fig. ... 945

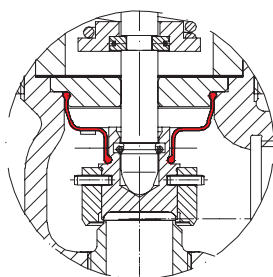

Fig. ... 945

EPDM-disc, soft seal insert; EPDM-bellow

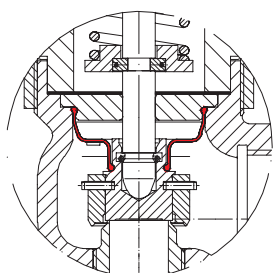

Fig. ... 946

Diisc metal seat, EPDM-Bellows seal

Figure	Nominal pressure	Material	Nominal diameter
25.945	PN40	EN-JS1049	DN15 - 25
Figure	Temperature range	Thread	
25.945	-10°C to +120°C	DIN ISO 228 Part 1	
Type-test approval			
spring loaded: TÜV · SV · . . . -997 · D/G/H (Fig. 945)			
Set gauge pressure refer to „Capacity“.			
Requirement			
Acc. to TRD 721 Part 6			
Application			
Acc. to DIN EN 12828 Heating systems in buildings			
Construction			
Standard safety valve, spring loaded, direct loaded disc with EPDM insert, EPDM-bellow, closed spring bonnet with control hole, open lifting device, stainless steel seat and spindle			
Sizing			
Acc. to TRD 721 Part 6.2.5, refer to „Capacity“.			
Order data:			
ARI-SAFE-TC - Safety valve, Figure, DN ... /, PN .. /, Material, Set gauge pressure bar			

Figure	Nominal pressure	Material	Nominal diameter
25.946	PN40	EN-JS1049	DN15 - 25
Figure	Temperature range	Thread	
25.946	-10°C to +120°C	DIN ISO 228 Part 1	
Type-test approval			
Low pressure steam - safety valve: TÜV · SV · . . . -997 · D (Fig. 946)			
Set gauge pressure refer to „Capacity“.			
Requirement			
Acc. to TRD 721 Part 5			
Application			
For low pressure steamgenerators up to 1 bar, DIN 4750 and DIN EN 12828 Heating systems in buildings			
Construction			
Standard safety valve, spring-/weight loaded, direct loaded with EPDM-bellow, closed bonnet with control hole, open lifting device, stainless steel seat and spindle			
Sizing			
refer to „Capacity“			
Order data:			
ARI-SAFE-TC - Safety valve, Figure, DN ... /, PN .. /, Material, Set gauge pressure ...bar			

Selection of possible applications

Heating facilities
(other applications on request)

Selection of possible flow media

Warm water, hot water
(other flow media on request)

Dimensions and weights

DN	(mm)	15	20	25	25
G	(inch)	1/2" x 3/4"	3/4" x 1"	1" x 1 1/4"	1" x 1 1/2"
d ₀	(mm)	12	15	18	18
A ₀	(mm)	113	177	254	254
GE	(inch)	1/2"	3/4"	1"	1"
GA	(inch)	3/4"	1"	1 1/4"	1 1/2"
b	(mm)	15	16	18	18
l	(mm)	50	50	50	50
l1	(mm)	53	55	58	58
H	(mm)	260	260	260	260
X	(mm)	120	120	120	120
Weight	(kg)	3,5	3,5	3,8	3,8

Spring ranges: Standard design (barg)

DN15	DN20	DN25
0,3 - 0,6	0,3 - 0,48	0,2 - 0,4
0,62 - 0,9	0,5 - 0,68	0,42 - 0,88
0,92 - 1,35	0,7 - 1,35	0,9 - 1,5
1,4 - 2,2	1,4 - 2,1	1,55 - 2,1
2,25 - 3,3	2,15 - 3	2,15 - 2,6
3,35 - 4,5	3,05 - 4	2,65 - 3,2
4,6 - 5,5	4,1 - 5,5	3,25 - 4,2
5,6 - 6,7	5,6 - 7,7	4,3 - 6,2
6,8 - 8,2	7,8 - 11,4	6,3 - 8
8,3 - 11	11,5 - 15	8,1 - 10
11,1 - 13	15,1 - 16	10,1 - 15,5
13,1 - 16		15,6 - 16

Parts

Pos.	Description	Fig. 25.945/946
1	Body	EN-GJS-400-18U-LT, EN-JS1049
2	Screwed seat	X6CrNiMoTi17-12-2, 1.4571
4	Spindle guide	X20Cr13+QT, 1.4021+QT
11	Bonnet, closed	EN-GJS-400-18U-LT, EN-JS1049
12	Disc unit	X6CrNiMoTi17-12-2, 1.4571
14	Spindle *	X20Cr13+QT, 1.4021+QT
17	Adjusting screw	X20Cr13+QT, 1.4021+QT
29	Cap, open	EN-GJS-400-18U-LT, EN-JS1049
37	Spring *	FDSiCr
41	Lever, open	EN-GJS-400-18U-LT, EN-JS1049
43	Bellow (optional)	EPDM
61	Coupling	X6CrNiMoTi17-12-2, 1.4571

* Spare parts

Information / restriction of technical rules need to be observed!

The engineer, designing a system or a plant, is responsible for the selection of the correct valve.

Fig. 945 Capacity saturated steam incl. 10% overpressure

Set gauge pressure in bar	Capacity	Saturated steam (kg/h), Heating capacity (kW)		
		Inlet diameter		
		DN 15	DN 20	DN 25
1,0	kg/h	72	103	188
	kW	44	63	115
1,5	kg/h	97	136	254
	kW	58	82	154
2,0	kg/h	120	172	320
	kW	72	103	191
2,5	kg/h	142	205	376
	kW	85	122	224
3,0	kg/h	162	238	430
	kW	96	140	253
3,5	kg/h	185	272	489
	kW	109	159	287
4,0	kg/h	206	300	545
	kW	120	176	316
4,5	kg/h	226	331	596
	kW	131	192	346
5,0	kg/h	246	360	650
	kW	142	208	375
5,5	kg/h	267	391	703
	kW	153	224	403
6,0	kg/h	285	420	755
	kW	164	240	432
6,5	kg/h	307	450	810
	kW	174	256	460
7,0	kg/h	325	480	860
	kW	185	271	488
7,5	kg/h	348	509	917
	kW	195	286	516
8,0	kg/h	370	540	970
	kW	206	302	543
9,0	kg/h	410	600	1075
	kW	227	332	598
10,0	kg/h	450	655	1180
	kW	247	362	651
11,0	kg/h	490	715	1290
	kW	267	391	705
12,0	kg/h	530	775	1395
	kW	287	421	757
13,0	kg/h	570	835	1500
	kW	307	449	809
14,0	kg/h	610	890	1605
	kW	326	478	860
15,0	kg/h	650	950	1710
	kW	346	506	911
16,0	kg/h	690	1010	1820
	kW	365	534	962

Calculated acc. to TRD 721 Part 6 and AD2000-A2

Fig. 946 Capacity saturated steam incl. 10% overpressure

Set gauge pressure in bar	Capacity	Saturated steam (kg/h)		
		Inlet diameter		
		DN 15	DN 20	DN 25
0,2	kg/h	--	--	67
0,3	kg/h	32	43	86
0,4	kg/h	38	53	103
0,5	kg/h	44	62	117
0,6	kg/h	50	71	133
0,7	kg/h	56	78	146
0,8	kg/h	62	86	163
0,9	kg/h	67	95	175
1,0	kg/h	72	103	188

Conversionrates:
 1 kW = 860 kcal/h* = 0,86 Mcal/h* = 3,6 MJ/h
 1 Mcal/h* = 1000 kcal/h* = 1,163 kW
 * not lawful units

Capacity water incl. 10% overpressure

Gauge press. bar	Water 20°C (kg/h)		
	Inlet diameter		
	DN 20	DN 25	DN 32
1	2700	3900	7000
2	3800	5600	10000
3	4700	6800	12400
4	5400	7900	14300
5	6000	8800	16000
6	6600	9700	17600
7	7200	10400	19000
8	7600	11200	20300
9	8100	11800	21600
10	8600	12500	22700
11	9000	13000	23800
12	9400	13700	24900
13	9800	14200	25900
14	10000	14800	26900
15	10500	15300	27900
16	10800	15800	28800

Sizing: 1 l/h $\hat{=}$ 1 kW
 Sizing safety valves for the volume flow of water expansion
 (DIN 4751 p2 - item 8.1)

ARI-SAFE-TCP - Standard safety valve D/G/F

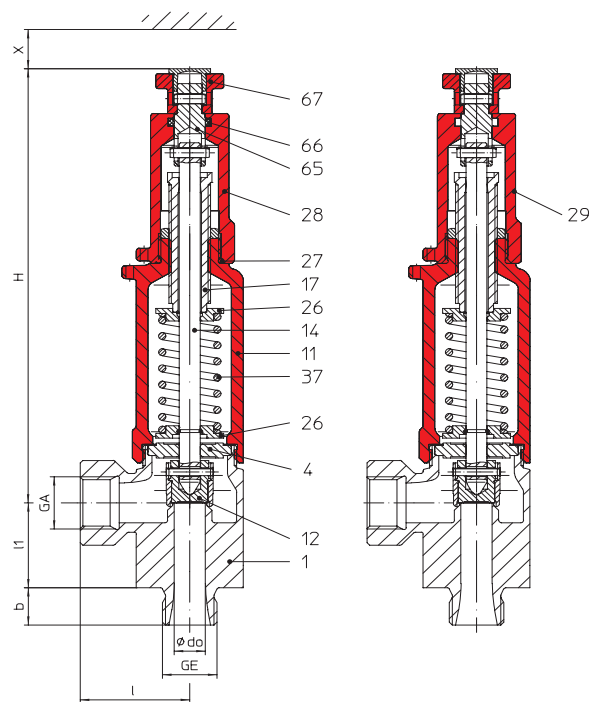

Fig. ...961
closed lifting device

Fig. ...962
open lifting device

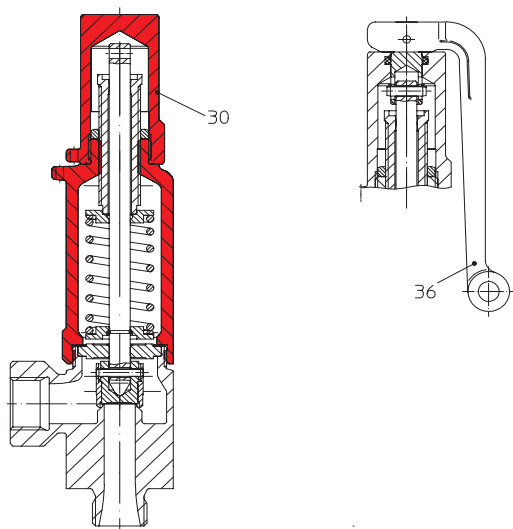

Fig. ...963
gastight cap

alternative with lever

Figure	Nominal pressure	Material	Nominal diameter
67.961 / 962 / 963	PN100	1.4581/EN-JS1049	DN15 - 25
57.961 / 963	PN100	1.4581	DN15 - 25
Figure	Temperature range	Thread	
67.961 / 962 / 963	-10°C to +300°C	DIN ISO 228 Part 1	
57.961 / 963	-60°C to +300°C	DIN ISO 228 Part 1	
Type-test approval			
Standard safety valve: TÜV · SV · . . -1041 · D/G/F (Fig. 961/962/963)			
Set gauge pressure refer to „Capacity“.			
Requirement			
Acc. to EN ISO 4126-1, VdTÜV-leaflet 100, AD2000-A2			
Construction			
Safety valve, spring loaded, direct loaded			
Sizing			
For steam, air and water see capacity tables, calculation acc. to EN ISO 4126-1, TRD 421 and AD2000-A2.			
Details required			
<ul style="list-style-type: none"> • Medium gasform: Mass flow (kg/h), molar mass (kg/kmol), temperature (°C), set gauge pressure (bar), back gauge pressure (bar) • Medium liquid: Mass flow (kg/h), density (kg/m³), viscosity, temperature (°C), Set gauge pressure (bar), back gauge pressure (bar) 			
Order data:			
ARI-SAFE-TCP - Safety valve, Figure, DN ... / ..., PN .. / ..., Material, Set gauge pressure bar			

Selection of possible applications

Chemical Industry, processing industry, plant manufacturing
(other applications on request)

Selection of possible flow media

1.4581/EN-JS1049: Steam, neutral gases, vapours and liquids
1.4581: Steam, aggressive gases, vapours and liquids
(other flow media on request)

	without metal bellow
Superimposed back pressure	no backpressure allowed
Built up back pressure	max. 10% from set pressure (gauge) (higher on request)

Dimensions and weights

DN	(mm)	15		20			25
G	(inch)	1/2" x 1/2"	1/2" x 3/4"	3/4" x 1/2"	3/4" x 3/4"	3/4" x 1"	1" x 1"
d ₀	(mm)	12	12	12	12	12	12
GE	(inch)	1/2"	1/2"	3/4"	3/4"	3/4"	1"
GA	(inch)	1/2"	3/4"	1/2"	3/4"	1"	1"
b	(mm)	15	15	16	16	16	18
l	(mm)	42	47	42	47	50	50
l1	(mm)	34	34	34	34	34	34
H	(mm)	189	189	189	189	189	189
X	(mm)	100	100	100	100	100	100
Weight	(kg)	1,2	1,2	1,2	1,2	1,2	1,2

Further connections on request.

Spring ranges: Standard design (barg)

DN15 - DN25
0,2 - 0,25
0,26 - 0,5
0,52 - 1
1,05 - 1,4
1,45 - 2,95
3 - 4,9
5 - 12
12,1 - 20
20,1 - 27
27,1 - 35
35,1 - 45
45,1 - 59
59,1 - 100

Parts

Pos.	Description	Fig. 67.961/962/963	Fig. 57.961/963
1	Body	GX5CrNiMoN19-11-2, 1.4581	
4	Spindle guide	X6CrNiMoTi17-12-2, 1.4571	
11	Bonnet, closed	EN-GJS-400-18U-LT, EN-JS1049	GX5CrNiMoN19-11-2, 1.4581
12	Disc unit	X6CrNiMoTi17-12-2, 1.4571	
14	Spindle *	X6CrNiMoTi17-12-2, 1.4571	
17	Adjusting screw	X6CrNiMoTi17-12-2, 1.4571	
27	O-ring	FPM	
28	Cap, closed	GX5CrNiMoN19-11-2, 1.4581	
29	Cap, open	GX5CrNiMoN19-11-2, 1.4581	
30	Cap, gastight	GX5CrNiMoN19-11-2, 1.4581	
36	Lever, closed (optional)	EN AC-4420 (Al)	
37	Spring *	FDSiCr	X10CrNi18-8, 1.4310
65	Coupling	X6CrNiMoTi17-12-2, 1.4571	
66	O-ring	FPM	
67	Lift button	X6CrNiMoTi17-12-2, 1.4571	

* Spare parts

Information / restriction of technical rules need to be observed!

The engineer, designing a system or a plant, is responsible for the selection of the correct valve.

Capacity saturated steam / air / water incl. 10% overpressure

Set gauge pressure in bar	I Saturated steam (kg/h)			II Air 0°C and 1.013 bara (Nm ³ /h)			III Water 20°C (t/h)		
	DN 15			DN 20			DN 25		
	G1/2" x G1/2"			G3/4" x G1/2"			G1" x G1"		
	G1/2" x G3/4"			G3/4" x G3/4"					
	G3/4" x G1"								
	do (mm)		12	12			12		
	I	II	III	I	II	III	I	II	III
0,2	14	16	0,62	14	16	0,62	14	16	0,62
0,5	24	29	0,98	24	29	0,98	24	29	0,98
1	35	44	1,39	35	44	1,39	35	44	1,39
2	56	71	1,97	56	71	1,97	56	71	1,97
3	75	96	2,41	75	96	2,41	75	96	2,41
4	96	125	2,78	96	125	2,78	96	125	2,78
5	116	150	3,11	116	150	3,11	116	150	3,11
6	135	176	3,41	135	176	3,41	135	176	3,41
7	153	201	3,68	153	201	3,68	153	201	3,68
8	172	227	3,93	172	227	3,93	172	227	3,93
9	191	252	4,17	191	252	4,17	191	252	4,17
10	210	277	4,40	210	277	4,40	210	277	4,40
11	229	303	4,61	229	303	4,61	229	303	4,61
12	248	328	4,82	248	328	4,82	248	328	4,82
13	267	354	5,01	267	354	5,01	267	354	5,01
14	286	379	5,20	286	379	5,20	286	379	5,20
15	304	405	5,39	304	405	5,39	304	405	5,39
16	323	430	5,56	323	430	5,56	323	430	5,56
17	342	455	5,73	342	455	5,73	342	455	5,73
18	361	481	5,90	361	481	5,90	361	481	5,90
19	380	506	6,06	380	506	6,06	380	506	6,06
20	399	532	6,22	399	532	6,22	399	532	6,22
25	494	659	6,95	494	659	6,95	494	659	6,95
30	590	786	7,62	590	786	7,62	590	786	7,62
35	686	913	8,23	686	913	8,23	686	913	8,23
40	784	1040	8,79	784	1040	8,79	784	1040	8,79
45	883	1165	9,33	883	1165	9,33	883	1165	9,33
50	983	1295	9,83	983	1295	9,83	983	1295	9,83
55	1085	1420	10,31	1085	1420	10,31	1085	1420	10,31
60	1185	1550	10,77	1185	1550	10,77	1185	1550	10,77
65	1290	1675	11,21	1290	1675	11,21	1290	1675	11,21
70		1800	11,63		1800	11,63		1800	11,63
75		1930	12,04		1930	12,04		1930	12,04
80		2055	12,44		2055	12,44		2055	12,44
85		2185	12,82		2185	12,82		2185	12,82
90		2310	13,19		2310	13,19		2310	13,19
95		2438	13,5		2438	13,5		2438	13,5
100		2565	13,76		2565	13,76		2565	13,76

max. set pressure stainless steel version

Certified coefficient of discharge Kdr (Values for D/G variable: < 4 bar)			
Kdr	15	20	25
D/G			0,30
F			0,23

ARI-SAFE-TCS - Standard safety valve D/G/F

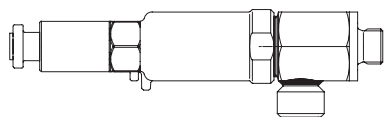

FOR HORIZONTAL APPLICATION

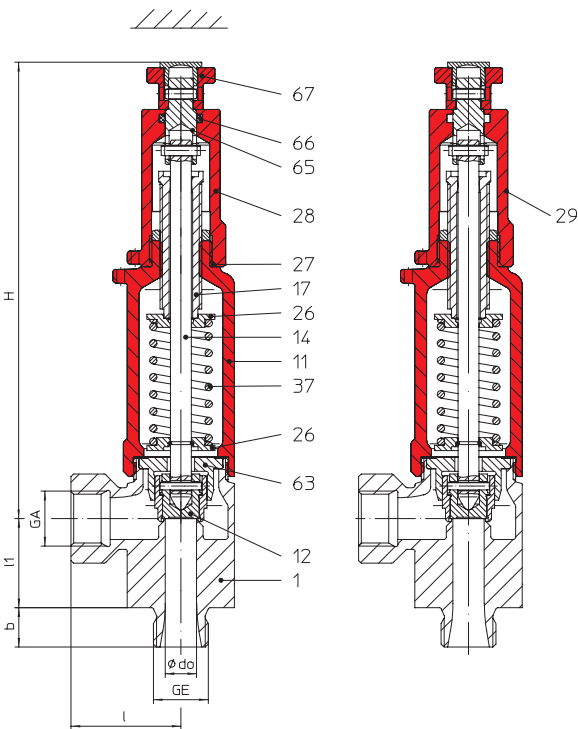

Fig. ...951
closed lifting device

Fig. ...952
open lifting device

Figure	Nominal pressure	Material	Nominal diameter
67.951 / 952 / 953	PN100	1.4581/EN-JS1049	DN15 - 25
57.951 / 953	PN100	1.4581	DN15 - 25
Figure	Temperature range	Thread	
67.951 / 952 / 953	-10°C to +300°C	DIN ISO 228 Part 1	
57.951 / 953	-60°C to +300°C	DIN ISO 228 Part 1	

Type-test approval

Standard safety valve: TÜV · SV · . . -1041 · D/G/F (Fig. 951/952/953)

Set gauge pressure refer to „Capacity“.

Requirement

Acc. to EN ISO 4126-1, VdTÜV-leaflet 100, AD2000-A2

Construction

Safety valve, spring loaded, direct loaded

Sizing

For steam, air and water see capacity tables, calculation acc. to EN ISO 4126-1, TRD 421 and AD2000-A2

Details required

- Medium gasform: Mass flow (kg/h), molar mass (kg/kmol), temperature (°C), set gauge pressure (bar), back gauge pressure (bar)
- Medium liquid: Mass flow (kg/h), density (kg/m³), viscosity, temperature (°C), Set gauge pressure (bar), back gauge pressure (bar)

Order data:

ARI-SAFE-TCP - Safety valve,
Figure, DN ... / ..., PN .. / ..., Material, Set gauge pressure bar

Selection of possible applications

Chemical Industry, processing industry, plant manufacturing
(other applications on request)

Selection of possible flow media

- 1.4581/EN-JS1049: Steam, neutral gases, vapours and liquids
- 1.4581: Steam, aggressive gases, vapours and liquids
(other flow media on request)

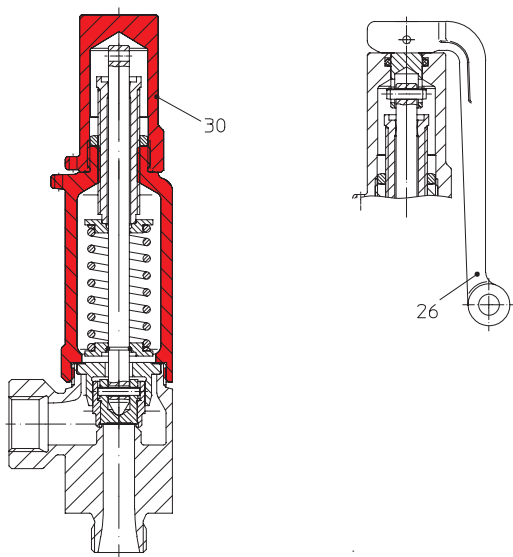

Fig. ...953
gastight cap

alternative with lever

Dimensions and weights

DN	(mm)	15		20			25
G	(inch)	1/2" x 1/2"	1/2" x 3/4"	3/4" x 1/2"	3/4" x 3/4"	3/4" x 1"	1" x 1"
d ₀	(mm)	12	12	12	12	12	12
GE	(inch)	1/2"	1/2"	3/4"	3/4"	3/4"	1"
GA	(inch)	1/2"	3/4"	1/2"	3/4"	1"	1"
b	(mm)	15	15	16	16	16	18
l	(mm)	42	47	42	47	50	50
l1	(mm)	34	34	34	34	34	34
H	(mm)	189	189	189	189	189	189
X	(mm)	100	100	100	100	100	100
Weight	(kg)	1,2	1,2	1,2	1,2	1,2	1,2

Further connections on request.

Spring ranges: Standard design (barg)

DN15 - DN25
0,2 - 0,25
0,26 - 0,5
0,52 - 1
1,05 - 1,4
1,45 - 2,95
3 - 4,9
5 - 12
12,1 - 20
20,1 - 27
27,1 - 35
35,1 - 45
45,1 - 59
59,1 - 100

Parts

Pos.	Description	Fig. 67.961/962/963	Fig. 57.961/963
1	Body	GX5CrNiMoN19-11-2, 1.4581	
11	Bonnet, closed	EN-GJS-400-18U-LT, EN-JS1049	GX5CrNiMoN19-11-2, 1.4581
12	Disc unit	X6CrNiMoTi17-12-2, 1.4571	
14	Spindle *	X6CrNiMoTi17-12-2, 1.4571	
17	Adjusting screw	X6CrNiMoTi17-12-2, 1.4571	
27	O-ring	FPM	
28	Cap, closed	GX5CrNiMoN19-11-2, 1.4581	
28	Cap, open	GX5CrNiMoN19-11-2, 1.4581	
28	Cap, gastight	GX5CrNiMoN19-11-2, 1.4581	
36	Lever, closed (optional)	EN AC-4420 (Al)	
37	Spring *	FDSiCr	X10CrNi18-8, 1.4310
63	Guide bush	X6CrNiMoTi17-12-2, 1.4571	
65	Coupling	X6CrNiMoTi17-12-2, 1.4571	
66	O-ring	FPM	
67	Lift button	X6CrNiMoTi17-12-2, 1.4571	

* Spare parts

Information / restriction of technical rules need to be observed!

The engineer, designing a system or a plant, is responsible for the selection of the correct valve.

Capacity saturated steam / air / water incl. 10% overpressure

Set gauge pressure in bar	I Saturated steam (kg/h)			II Air 0°C and 1.013 bara (Nm ³ /h)			III Water 20°C (t/h)		
	DN 15			DN 20			DN 25		
	G1/2" x G1/2"			G3/4" x G1/2"			G1" x G1"		
	G1/2" x G3/4"			G3/4" x G3/4"					
				G3/4" x G1"					
	do (mm) 12			12			12		
	I	II	III	I	II	III	I	II	III
0,5	20	24	0,81	20	24	0,81	20	24	0,81
1	30	37	1,15	30	37	1,15	30	37	1,15
2	48	62	1,62	48	62	1,62	48	62	1,62
3	68	86	1,99	68	86	1,99	68	86	1,99
4	84	108	2,30	84	108	2,30	84	108	2,30
5	100	130	2,57	100	130	2,57	100	130	2,57
6	117	152	2,81	117	152	2,81	117	152	2,81
7	133	174	3,04	133	174	3,04	133	174	3,04
8	149	196	3,25	149	196	3,25	149	196	3,25
9	166	218	3,45	166	218	3,45	166	218	3,45
10	182	240	3,63	182	240	3,63	182	240	3,63
11	198	262	3,81	198	262	3,81	198	262	3,81
12	215	284	3,98	215	284	3,98	215	284	3,98
13	231	306	4,14	231	306	4,14	231	306	4,14
14	247	328	4,3	247	328	4,3	247	328	4,3
15	264	351	4,45	264	351	4,45	264	351	4,45
16	280	373	4,59	280	373	4,59	280	373	4,59
17	297	395	4,74	297	395	4,74	297	395	4,74
18	313	417	4,87	313	417	4,87	313	417	4,87
19	329	439	5,01	329	439	5,01	329	439	5,01
20	346	461	5,14	346	461	5,14	346	461	5,14
25	428	571	5,74	428	571	5,74	428	571	5,74
30	512	681	6,29	512	681	6,29	512	681	6,29
35	595	791	6,80	595	791	6,80	595	791	6,80
40	680	901	7,26	680	901	7,26	680	901	7,26
45	765	1010	7,71	765	1010	7,71	765	1010	7,71
50	852	1120	8,12	852	1120	8,12	852	1120	8,12
55	940	1230	8,52	940	1230	8,52	940	1230	8,52
60	1030	1340	8,90	1030	1340	8,90	1030	1340	8,90
65	1120	1450	9,26	1120	1450	9,26	1120	1450	9,26
70		1560	9,61		1560	9,61		1560	9,61
75		1675	9,95		1675	9,95		1675	9,95
80		1785	10,27		1785	10,27		1785	10,27
85		1895	10,59		1895	10,59		1895	10,59
90		2005	10,90		2005	10,90		2005	10,90
95		2110	11,16		2110	11,16		2110	11,16
100		2220	11,36		2220	11,36		2220	11,36

From 0,5 - 4,9 bar, adjustment - horizontal.

Certified coefficient of discharge Kdr (Values for D/G variable: < 3 bar)			
Kdr	15	20	25
D/G		0,26	
F		0,19	

	SAFE Fig. 900			SAFE-P Fig. 920	SAFE-TC Fig. 940			SAFE- TCS/ TCP Fig. 950 / 960
	Fig. 901-912	Fig. 903	Fig. 904	Fig. 921-924	Fig. 941-943	Fig. 945	Fig. 946	Fig. 951-953 Fig. 961-963
Pressure equipment directive PED 97/23/ EG Module H1, B+D	X	X	X	X	X	X	X	X
BV Bureau Veritas Frankreich / France	X	--	--	X	X	--	--	--
DNV Det Norske Veritas Norwegen / Norway	X	--	--	X	X	--	--	--
GL Germanischer Lloyd	X	--	--	X	X	--	--	X
LROS (LRS) Lloyds Register of Shipping	X	--	--	X	X	--	--	--
SELO (SQLO) China / Chine	X	X	X	X	X	X	X	X
ASME Code Section VIII-Division 1 (UV-stamp)	X	--	--	--	--	--	--	--
Canada Registration (UV-stamp)	X	--	--	--	--	--	--	--
GOST-R Russland / Russia	X	X	X	X	X	X	X	X
RMROS (RS) Russian Maritime Register of Shipping	X	X	X	X	X	X	X	X
Promatomnadzor White russia (Rep. of Belarus)	X	X	X	X	X	X	X	X
Prombezpeka Ukraine	X	X	X	X	X	X	X	X
Rostechnadzor (Gosgortechnadzor) Russland / Russia	X	X	X	X	X	X	X	X

Single approvals

Arbejdstilsynet Danish employment protection	X	X	X	X	X	X	X	X
ABS American Bureau of Shipping	X	X	X	X	X	X	X	X
AIB Vincotte Belgien / Belgium	X	X	X	X	X	X	X	X
IBR Indien Boiler Regulations	X	--	--	X	X	--	--	--
ISPESL Italien / Italy	X	X	X	X	X	X	X	X
RINA Italien / Italy	X	--	--	X	X	--	--	--
Stoomwezen Niederlande / Netherlands	X	X	X	X	X	X	X	X
NK Japan	X	X	X	X	X	X	X	X
UDT Polen / Poland	X	X	X	X	X	X	X	X

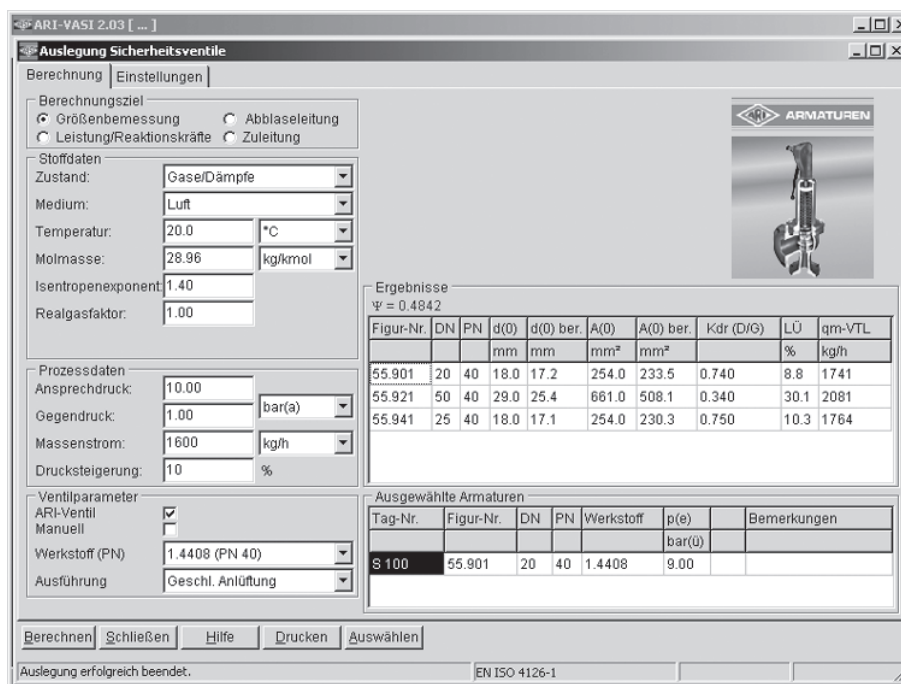

ARI-VASI® - Valve Sizing-Program

Contents:

(Program part Safety valves)

- Sizing (Calculation of valve-size with given capacity.)
- Capacity / reaction forces (Capacity and reaction forces calculation with given valve.)
- Back pressure in the outlet pipe (complete back pressure calculation in the outlet pipe.)
- Pressure drop in the inlet pipe (Allowable resistance coefficient and max. inlet pipe dimension calculation.).

Media:

Integrated media-databank
(over 160 Media) with conditions:

- Vapours / gases
- Steam (saturated and superheated)
- Liquids
- Hot water
- Thermal expansion

Special features:

- Project administration for the chosen safety valves together with control valves, pressure reducing valves, stop valves and butterfly valves.
- SI- and ANSI-units with direct conversion to another databank.
- All ARI safety valves are integrated in a databank.
- Resistance coefficients of elbows and T-fittings integrated.
- Direct switch over of languages (German / English) separated to the screen and print.

System Requirements:

WINDOWS 95 / 98 / NT / 2000 or XP



Standard-flange dimensions SAFE Fig. 901-912, 903, 904

Flange holes / -thickness tolerances acc. to DIN 2533/2544/2545

DN1 / DN2		(mm)	20 / 32	25 / 40	32 / 50	40 / 65	50 / 80	65 / 100	80 / 125	100 / 150	125 / 200	150 / 250
ØD1	PN16 DIN 2533	(mm)	105	115	140	150	165	185	200	220	250	285
	PN40 DIN 28607	(mm)								235	270	300
	PN40 DIN 2545	(mm)										
ØD2	PN16 DIN 2533	(mm)	140	150	165	185	200	220	250	285	340	405
	PN16 DIN 28605	(mm)										
	PN16 DIN 2543	(mm)										
b1	EN-JL1040	(mm)	16	16	18	18	20	20	22	24	26	26
	EN-JL1049	(mm)	18	18	18	19	20	22	24	24	--	--
	1.0619+N	(mm)	20	20	20	21	22	24	26	28	31	34
	1.4408	(mm)	16	16	18	19	20	22	22	23	--	--
b2	EN-JL1040	(mm)	18	18	20	20	22	24	26	26	30	32
	EN-JL1049	(mm)	19	19	20	20	20	20	22	22	--	--
	1.0619+N	(mm)	19	19	20	20	20	20	22	22	27	29
	1.4408	(mm)	15	16	17	17	17	17	19	19	--	--

Flanges acc. to DIN EN 1092-1 / -2, Flangeholes/-thickness tolerances acc. to DIN, raised face, facing acc. to DIN 2526 form C

Standard-flange dimensions SAFE-P Fig. 921-924

Flange holes / -thickness tolerances acc. to DIN 2533/2544/2545

DN		(mm)	20	25	32	40	50	65	80	100
ØD	PN16 DIN 2533	(mm)	105	115	140	150	165	185	200	220
	PN40 DIN 2545	(mm)								235
b	EN-JL1040	(mm)	16	16	18	18	20	20	22	24
	1.0619+N	(mm)	18	18	18	18	20	20	22	24
	1.4408	(mm)	18	18	18	18	20	20	22	24

Flanges acc. to DIN EN 1092-1 / -2, Flangeholes/-thickness tolerances acc. to DIN, raised face, facing acc. to DIN 2526 form C

Standard-flangeholes

Flange holes / -thickness tolerances acc. to DIN 2533/2544/2545

DN		(mm)	20	25	32	40	50	65	80	100	125	150	200	250
PN16	ØK	(mm)	75	85	100	110	125	145	160	180	210	240	295	355
	n x Ød	(mm)	4x14	4x14	4x18	4x18	4x18	4x18	8x18	8x18	8x18	8x22	12x22	12x26
PN40	ØK	(mm)	75	85	100	110	125	145	160	190	220	250	--	--
	n x Ød	(mm)	4x14	4x14	4x18	4x18	4x18	8x18	8x18	8x22	8x26	8x26	--	--

Pressure-temperature-ratings acc. to DIN EN 1092-2

Material	PN		-60°C to <-10°C	-10°C to 120°C	150°C	200°C	250°C	300°C	350°C	400°C	450°C
EN-JL1040	16	bar	--	16	14,4	12,8	11,2	9,6	--	--	--
EN-JS1049	40	bar	on request	40	38,8	36,8	34,8	32	28	--	--

Pressure-temperature-ratings acc. to DIN EN 1092-1

Material	PN		-60°C to <-10°C	-10°C to 50°C	100°C	150°C	200°C	250°C	300°C	350°C	400°C	450°C
1.0619+N	40	bar	30	40	37,3	34,7	30,2	28,4	25,8	24	23,1	22,2
1.4408	40	bar	40	40	37,3	33,8	31,1	29,3	27,6	26,7	25,6	--
1.4581	100	bar	50	100	97,8	91,1	85,3	81,3	77,8	75,1	72,9	--

Intermediate values for max. permissible operational pressures can be determined by linear interpolation of the given temperature / pressure chart.

* Studs and nuts made of A4-70 (at temperatures below -10°C)

 Dimensions in mm
 Weights in kg
 Pressures in barg (gauge)
 1 bar $\hat{=}$ 10⁵ Pa $\hat{=}$ 0,1 MPa
 Kvs in m³/h

Soft sealing disc: WEDI

 EPDM -35 °C to +150 °C Abbreviation **E**

 Viton (FPM) -25 °C to +180 °C Abbreviation **V**

 Neoprene (CR) -30 °C to +125 °C Abbreviation **N**

Bellows seal EPDM (max. +120 °C)

Disc: metal seat or WEDI

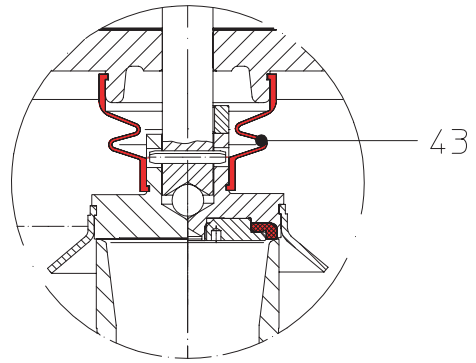

Soft sealing disc WEDI / Bellows seal EPDM

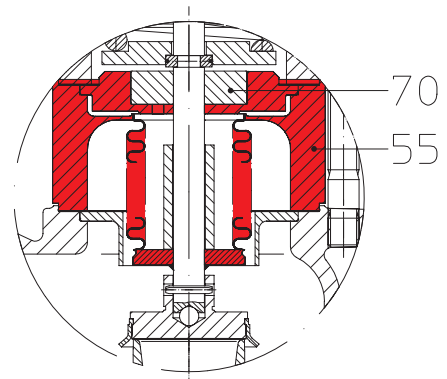

Bellow - stainless steel

(Test: german TA-Luft TÜV-Test-No.. 922-960324)

Balanced stainless steel-bellow with balanced piston (Only for closed version!)

Parts

Pos.	Description	
43	Bellow (optional)	EPDM
55	Bellow unit (optional)	X6CrNiMoTi17-12-2, 1.4571
70	Balanced piston (optional)	X6CrNiMoTi17-12-2, 1.4571

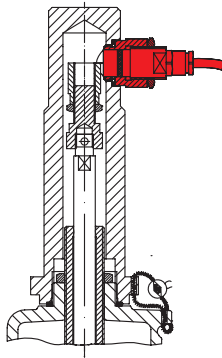

Proximity switch

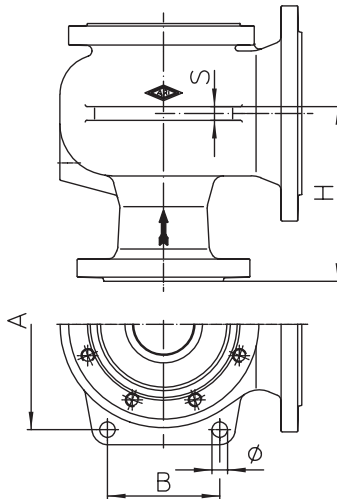

Body material	DN1 x DN2	A	B	Ø	S	H
1.0619+N	50 x 80	176	70	14	12	155
1.4408	65 x 100	212	90			175
EN-JL1040	80 x 125	245	130	18	16	205
EN-JS1049						230
1.0619+N	100 x 150	295	165	22	20	260
1.4408						295
EN-JL1040	125 x 200	318	183	22	22	260
1.0619+N	150 x 250	360	200			295

Support tongues

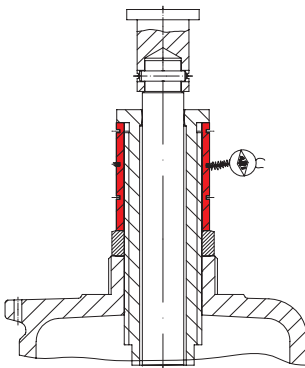

Lock bushing

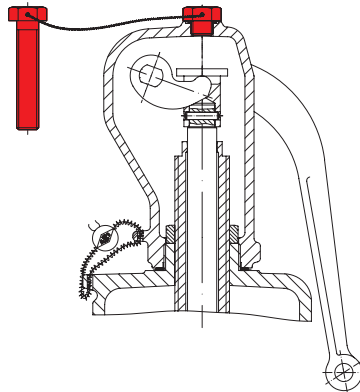

Test gag

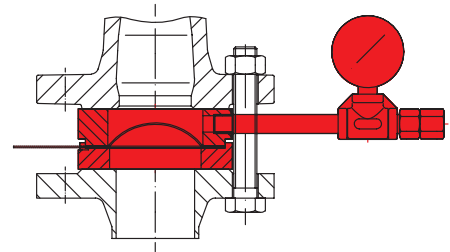

Rupture disc

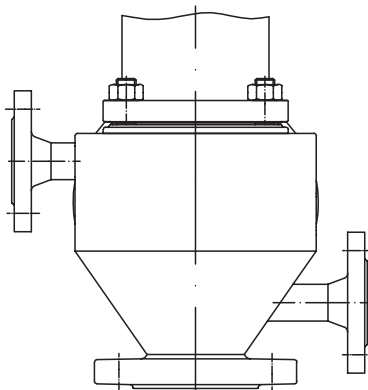

Heating jacket

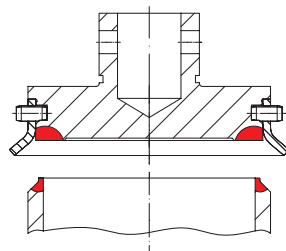

Seat 1.4571 / Stellite No. 21
Disc 1.4571 / Stellite No. 6
and removable lifting aid

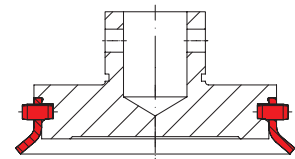

Removable lifting aid Chemical-version 1.4571